

**ANALYSIS AND OPTIMIZATION OF
TRANSMISSION RESONANCES
THROUGH PERIODIC
PLASMONIC
STRUCTURES**

by

Hwan Yong Lee

A dissertation submitted to the faculty of
The University of Utah
in partial fulfillment of the requirements for the degree of

Doctor of Philosophy

Department of Mathematics

The University of Utah

August 2010

Copyright © Hwan Yong Lee 2010

All Rights Reserved

The University of Utah Graduate School

STATEMENT OF DISSERTATION APPROVAL

The dissertation of _____ **Hwan Yong Lee** _____

has been approved by the following supervisory committee members:

_____ David Dobson _____	, Chair	_____ 06/16/2010 _____ Date Approved
_____ Alexander Balk _____	, Member	_____ 06/11/2010 _____ Date Approved
_____ Andrej Cherkaev _____	, Member	_____ 06/11/2010 _____ Date Approved
_____ Elena Cherkaev _____	, Member	_____ 06/11/2010 _____ Date Approved
_____ Jingyi Zhu _____	, Member	_____ 06/11/2010 _____ Date Approved

and by _____ **Aaron Bertram** _____, Chair of
the Department of _____ **Mathematics** _____

and by Charles A. Wight, Dean of The Graduate School.

ABSTRACT

This dissertation is focused on electromagnetic wave propagation through periodic structures. The work consists of two main parts. In the first part we deal with electromagnetic radiation through periodic aperture arrays in an “infinitesimally thin perfect electric conductor”. Electromagnetic radiation through a bounded medium with two-dimensional geometry and finite width is considered as the second model.

First of all, we formulate a mathematical model for electromagnetic transmission through periodic hole arrays in a thin perfect electric conductor, where we can obtain an explicit linear operator equation for the tangential components of the electric and magnetic fields inside the apertures. The linear operator is regularized to ensure a stable numerical solution. We then analyze the solvability of the linear operator equation with a truncated, regularized and mollified operator. The extension of our model to the case of an arbitrary incoming wave by adding a Bloch condition is included. We establish the conservation of energy, stating that the total energy of the reflected and transmitted waves is equal to the energy of the incident wave. We then introduce some numerical experiments and show numerically that energy dissipation occurs with the regularization.

As the second model, we consider electromagnetic radiation through a bounded medium. It is assumed that the material parameters are constant in one direction, so that the problem can be formulated in two-dimensional geometries for appropriate polarizations. We investigate time-harmonic electromagnetic wave propagation through nonmagnetic heterogeneous media for which the complex dielectric coefficients have opposite signs in the real part. It is known that the imaginary part accounts for energy absorption. We formulate an equivalent variational problem over a bounded region with transparent boundary conditions and then show that the problem has a unique solution over all range of incidence angles, provided energy dissipation is present. The problem of designing a structure for which a desired transmission energy spectrum is attained, is considered. The optimal design problem is stated as a minimization problem. We then show that the minimization problem with an appropriate admissible set has at least one solution. We present the numerical experiment that indicates surface plasmons occur at the interface of some structure and then show the

numerical experiment of the transmission energy spectrum for some structure for a various value of the dielectric coefficient.

To my family.

CONTENTS

ABSTRACT	iii
LIST OF FIGURES	viii
ACKNOWLEDGEMENTS	x
CHAPTERS	
1. INTRODUCTION	1
1.1 Basic model equations	1
1.2 Surface plasmons	3
1.3 Electromagnetic transmission through periodic aperture arrays	3
1.4 Optimization of transmission spectra through periodic plasmonic structures	5
1.5 Mathematical preliminaries	6
1.6 Outline	8
2. DIFFRACTION THROUGH A PERIODIC APERTURE ARRAY IN A PERFECT CONDUCTOR	11
2.1 Model problem	11
2.2 Problem formulation	11
2.3 Regularization, existence and uniqueness	14
2.4 Extension to arbitrary incoming wave	20
2.5 Conservation of energy	22
2.5.1 Conservation of energy for an unregularized operator	22
2.5.2 Energy dissipation for an regularized operator	28
2.6 Numerical experiments	29
3. OPTIMIZATION OF TRANSMISSION SPECTRA THROUGH PERIODIC APERTURE ARRAYS	43
3.1 Model problem	43
3.2 Existence and uniqueness of solutions for TE-polarization	46
3.3 Existence and uniqueness of solutions for TM-polarization	50
3.3.1 Optimal design	54
3.3.1.1 Minimization problem	54
3.4 Numerical experiments	56

4. CONCLUSIONS	63
REFERENCES	65

LIST OF FIGURES

1.1	Four different aperture shapes. (Figure taken from [9])	9
1.2	Magnitude of the normalized amplitude transmission spectra for Array A and B.(Figure taken from [9])	9
1.3	Magnitude of the normalized amplitude transmission spectra for Array B-E.(Figure taken from [9])	10
2.1	Problem geometry for periodic hole arrays.	33
2.2	Problem geometry for energy conservation.	33
2.3	Three components of E field for the hole array of circles in the (x_1, x_2) -plane at frequency $\omega = 0.7$. Top is E field with the regularization parameter $\delta = 0$, middle is with $\delta = 0.05$, bottom is with $\delta = 0.05$, height 0.15	34
2.4	Three components of E field for the hole array of rectangles in the (x_1, x_2) -plane at frequency $\omega = 0.7$. Top is E field with the regularization parameter $\delta = 0$, middle is with $\delta = 0.05$, and bottom is with $\delta = 0.05$, height 0.15	35
2.5	Transmission T (black solid line), total energy spectrum $R + T$ (blue dash-dotted line) and relative energy spectrum $T/(R + T)$ (red dashed line) for the hole array of circles computed using different values of δ . Top : $\delta = 0$, bottom : $\delta = 0.001$	36
2.6	Transmission T (black solid line), total energy spectrum $R + T$ (blue dash-dotted line) and relative energy spectrum $T/(R + T)$ (red dashed line) for the hole array of circles computed using different values of δ . Top : $\delta = 0.01$, bottom : $\delta = 0.1$	37
2.7	Transmission T (black solid line), total energy spectrum $R + T$ (blue dash-dotted line) and relative energy spectrum $T/(R + T)$ (red dashed line) for the hole array of rectangles computed using different values of δ . Top : $\delta = 0$, bottom : $\delta = 0.001$	38
2.8	Transmission T (black solid line), total energy spectrum $R + T$ (blue dash-dotted line) and relative energy spectrum $T/(R + T)$ (red dashed line) for the hole array of rectangles computed using different values of δ . Top : $\delta = 0.01$, bottom : $\delta = 0.1$	39
2.9	Comparison of transmission T for the hole array of circles (red solid line) and transmission T for the hole array of rectangles (blue dashed line).	40
2.10	Eigenvalue distribution of operator A_δ for the hole arrays of circles with $\delta = 0$ (blue o) and $\delta = 0.01$ (red x).	41
2.11	Energy dissipation for the hole arrays of circles (blue solid line), and rectangles (red dashed line).	42

3.1 Problem geometry for periodic plasmonic structure.	58
3.2 Surface plasmons (bottom) at the interface of the structure (top).	59
3.3 Transmission energy epectrum with imaginary part $\rho_i = 0$ (top), $\rho_i = 0.00001$ (bottom) for the structure Figure 3.5.	60
3.4 Transmission energy epectrum with imaginary part $\rho_i = 0.0001$ (top) $\rho_i =$ 0.002 (bottom) for the structure Figure 3.5.	61
3.5 The structure for transmission energy spectrum.	62

ACKNOWLEDGEMENTS

First of all, I would like to thank Professor David Dobson, my thesis advisor, for guiding me into this research area, and for his devoted help and advice. Whenever I was exhausted and frustrated, he encouraged and stimulated me to refresh and continue the research. Without him, I would never have done this dissertation. I am so lucky to have him as my advisor. His valuable advice and enthusiasm for research will guide me to the right path in my future career.

I would also like to express my thanks to committee members, Professor Andrej Cherkaev, Elena Cherkaev, Jingyi Zhu and Alexander Balk, for their encouragement and advice on this research. Their criticism, insights and support have been an indispensable component of my research.

I also wish to thank all members in Math Department for their help and friendships. With them, I have really enjoyed my school days.

I would like to express my special thanks to Dr. Beebe for his sincere help in typing my dissertation.

I am very grateful to Prof. KilHyun Kwon at KAIST in Korea for his valuable advice and encouragement. I still remember his enthusiasm for research that he showed me when I was in the master's course.

I would also like to thank Prof. Sukzun Song, Youngoh Yang, Eunsook Bang, Yongsik Yoon and Seungdal Jung at Cheju National University in Korea for their concern and thoughtful consideration.

Lastly, I am deeply grateful to my wife, Min Jeong, for her dedicated support and love, and I would like to say to love her and our unborn daughter. I also wish to thank my family, my mother and my sisters for their devotion. They have always supported me with unconditional love.

I would like to dedicate this dissertation to my father and grandmother in heaven.

CHAPTER 1

INTRODUCTION

Throughout this dissertation, we discuss electromagnetic transmission through periodic plasmonic structures. This dissertation works on two main models. The first model is about electromagnetic transmission through periodic hole arrays in an infinitesimally thin perfect electric conductor and the other is about electromagnetic radiation through a bounded medium with a finite width and the optimal design of structures.

In this chapter, we give a brief introduction for each problem. We describe the basic equations which govern our models and introduce some mathematical preliminaries which are used in this dissertation. Lastly, we mention a brief outline of the dissertation.

1.1 Basic model equations

This dissertation concerns electromagnetic wave propagation through periodic plasmonic structures and it is modelled and determined by Maxwell's equations. The macroscopic Maxwell's equations that govern the light propagation in the absence of free charges and currents are given as follows:

$$\nabla \times E = -\frac{1}{c} \frac{\partial B}{\partial t}, \quad \nabla \cdot B = 0, \quad (1.1)$$

$$\nabla \times H = \frac{1}{c} \frac{\partial D}{\partial t}, \quad \nabla \cdot D = 0, \quad (1.2)$$

where c is the speed of light, E and H are the electric and magnetic fields, and D and B are the displacement and magnetic induction fields, respectively. Here we consider only linear isotropic media, so that the fields D and H depend on E and B , and their relationship can be described by the constitutive relations:

$$D = \epsilon E, \quad B = \mu H,$$

where ϵ and μ are the scalar-valued electric permittivity and magnetic permeability, respectively. Introducing the above assumptions, Maxwell's equations can be reduced to the form

$$\nabla \times E = -\frac{1}{c} \mu \frac{\partial H}{\partial t}, \quad \nabla \cdot \mu H = 0, \quad (1.3)$$

$$\nabla \times H = \frac{1}{c} \epsilon \frac{\partial E}{\partial t}, \quad \nabla \cdot \epsilon E = 0. \quad (1.4)$$

We now consider time-harmonic electromagnetic wave propagation with time dependence $e^{-i\omega t}$. Then equations (1.3),(1.4) reduce to the form

$$\nabla \times E = i\omega\mu H, \quad \nabla \cdot \mu H = 0, \quad (1.5)$$

$$\nabla \times H = -i\omega\epsilon E, \quad \nabla \cdot \epsilon E = 0. \quad (1.6)$$

Here c has been absorbed into the frequency ω .

Throughout this dissertation, we only consider the nonmagnetic case ($\mu = 1$).

In general, the electric permittivity ϵ is the complex-valued function of frequency ω . If the medium is conducting with the nonzero conductivity σ , a current J , defined $J = \sigma E$, will flow, and the equation (1.6) should be changed into

$$\begin{aligned} \nabla \times H &= (-i\omega\epsilon + \sigma)E \\ &= -i\omega \left(\epsilon - \frac{\sigma}{i\omega} \right) \\ &= -i\omega\epsilon_c E, \end{aligned}$$

where $\epsilon_c = \epsilon - \frac{\sigma}{i\omega}$.

The other equations (1.5),(1.6) are kept unchanged. Therefore, those equations for non-conducting media above can be applied to conducting media with the complex permittivity ϵ_c and we note that ϵ_c depends on the frequency ω .

If the material parameters are independent of one of the coordinates, we end up with a two-dimensional medium. Let us assume that $\epsilon(x_1, x_2, x_3) = \epsilon(x_1, x_2)$, that is, the underlying structure is constant in the x_3 -direction. If we assume that the electromagnetic field (E, H) is also independent of x_3 , there are two fundamental cases, depending on the direction and polarization of the incident wave :

1. TE (transverse electric) polarization : the incidence vector is orthogonal to the x_3 -axis and the electric field E is parallel to x_3 .

Assuming that the electric field $E = (0, 0, u(x_1, x_2))$, the Maxwell's equations (1.5),(1.6) reduce to the scalar Helmholtz equation

$$\Delta u + \omega^2 \epsilon(x) u = 0 \quad (\text{TE-polarization}). \quad (1.7)$$

2. TM (transverse magnetic) polarization : the incidence vector is orthogonal to the x_3 -axis and the electric field H is parallel to x_3 .

Assuming that the electric field $H = (0, 0, u(x_1, x_2))$, the Maxwell's equations (1.5),(1.6) reduce to the scalar model

$$\nabla \cdot \left(\frac{1}{\epsilon(x)} \right) \nabla u + \omega^2 u = 0 \quad (\text{TM-polarization}). \quad (1.8)$$

1.2 Surface plasmons

When incoming photons strike a metal film, surface electrons oscillate and propagate along the surface of the metal film. The oscillation is known as a surface plasmon polariton (SPP). The oscillation excitation can confine light and carry electromagnetic energy along the surface. With periodic nano-sized hole arrays, SPPs can carry energy through holes even though the hole size is much smaller than the wavelength of the incoming wave. Such extraordinary transmission through subwavelength hole arrays has been well established in [15, 20]. SPPs can exist at the interface between two materials that have different signs for the real parts of their dielectric constants, for example, a metal film in air. One of characteristics of SPPs is that in “two-dimensional” geometries, SPPs exist only for TM (transverse magnetic)-polarization. The study of plasmonics has become one of the most promising areas in photonics due to its potential applications. A detailed, well-organized introduction to the field of plasmonics is given in [30].

Inspired by the potential of the field, we investigate electromagnetic wave propagation through plasmonic structures and introduce a framework for the design of optimal structures for a prescribed energy transmission spectrum.

1.3 Electromagnetic transmission through periodic aperture arrays

Electromagnetic wave transmission through aperture arrays has been studied for many years. The diffraction of electromagnetic radiation by a hole small compared with the wavelength has been of great interest and was treated theoretically in [2, 27, 32]. Once an incident electromagnetic wave propagates through holes much smaller than the wavelength of the incident photon, significantly enhanced transmission can be obtained at some frequencies. The research regarding such unusual phenomena has brought tremendous interest, due to its applications and contributions to novel photonic devices. Such interesting phenomena have been studied in [15, 17, 20, 31, 21].

In the paper [15], T.W. Ebbesen, H.J. Lezec, H.F. Ghaemi, T.Thio and P.A. Wolff examined light transmission through periodic hole arrays in metal film with dependence

on all the possible variables such as hole diameter, periodicity, thickness and type of metal. They then demonstrated that the position of the transmission resonances and the transmission intensity were determined by the periodicity of hole arrays, and the width of resonance peaks appeared to be dependent upon the ratio of the film thickness to the individual hole diameter. They concluded that the enhancement of transmitted light was caused by coupling of the light with the surface plasmon polaritons that propagate along the interface of the metal film, using the result that no enhancement transmission in hole arrays fabricated in *Ge* films occurred.

Several studies have explored and demonstrated this phenomenon at terahertz radiation frequencies. Hua Cao and Ajay Nahata examined terahertz radiation through aperture arrays fabricated in $75\mu\text{m}$ thick stainless steel foils. They showed that the amplitude transmission coefficients at terahertz frequencies were significantly larger than those observed at visible frequencies, and the resonance linewidths at terahertz frequencies were narrower than those at visible frequencies [8]. It has been demonstrated experimentally that the resonantly enhanced transmission spectrum associated with a periodic array of subwavelength apertures is dependent upon the shape of the apertures, and that significant transmission resonances are evident only in the periodic arrays [9]. Hua Cao and Ajay Nahata used four different aperture shapes in their investigation. See Figure 1.1. They measured the transmitted THz electric field using Time-domain THz spectroscopy for periodic arrays A,B,C and D of the four different aperture shapes, and for the aperiodic array E of square apertures. Array A consists of $400\ \mu\text{m}$ diameter circular apertures, Array B consists of $400\ \mu\text{m} \times 400\ \mu\text{m}$ square apertures, Array C consists of $400\ \mu\text{m} \times 300\ \mu\text{m}$ rectangular apertures, Array D consists of $400\ \mu\text{m} \times 200\ \mu\text{m}$ rectangular apertures, and Array E consists of $400\ \mu\text{m} \times 400\ \mu\text{m}$ square apertures. Figure 1.2 and Figure 1.3 show the magnitude of the normalized amplitude transmission coefficient versus THz frequency for the five aperture arrays. From those figures, it is obvious that the magnitude of the transmission coefficient is dependent upon the aperture shape, and the square aperture array displays the largest transmission resonance among all type arrays. One of the remarkable results is that no significant transmission resonances occur for the aperiodic array.

The periodic structure is considered to be crucial for the transmission resonances. But it has been shown that sharp transmission resonances can be obtained from quasiperiodic aperture arrays, as well as more generalized aperiodic aperture structures in metal film [24].

Using this interesting phenomenon, it is hoped that one can create filters which selec-

tively transmit energy in certain frequency ranges and reject others. The optimal design of hole structures that can control the transmitted energy has been discussed in [12].

These significant phenomena have created great interest in controlling and manipulating energy, with various potential applications, including broadband communications. Therefore, theoretical analysis of these phenomena would be useful for more understanding and direction toward novel applications.

1.4 Optimization of transmission spectra through periodic plasmonic structures

This dissertation concerns nonmagnetic ($\mu=1$) heterogeneous media that have opposite signs for dielectric constants, for example, a metal film in air. Once a metallic film is placed in electromagnetic field, a plasma oscillation, which is a collection of longitudinal excitations of the conduction electron gas, can be excited along the interface between the metal and air, due to the coupling of the charge of the electron with the electrostatic field fluctuations of the plasma oscillation. The excitation allows unexpected energy transport along the interface and through the metal.

Electromagnetic materials that have negative values for the electric permittivity and/or magnetic permeability have recently brought significant research interest. Interaction of electromagnetic waves with materials having refractive index of -1 was first introduced by Veselago [35] and he named such materials the left-handed materials (LHMs). The refractive index n is expressed in terms of the permittivity ϵ and the permeability μ , $n = \pm\sqrt{\epsilon\mu}$. Veselago insisted and proved that the material having the negative permittivity and the negative permeability simultaneously should be possible and the refractive index n must take the negative sign of the square root for such materials. The negative refractive index yields different properties from conventional materials. Due to the extraordinary effect of LHMs, LHMs have become a hot issue and are applied to many potential applications, for example, superlenses [28] and the design of cloaking devices [5, 22, 25, 29, 34]. Such topics are however outside the scope of this thesis.

For practical applications, it is natural to study electromagnetic wave transmission near interfaces between media with opposite signs for dielectric constants. In fact, most common metals (gold, silver, aluminum and so on) exhibit a negative real dielectric constant in optical frequency ranges [19]. In two-dimensional configurations, the electromagnetic wave transmission problem can be described by the following scalar equation

$$\nabla \cdot \frac{1}{\epsilon} \nabla u + \omega^2 \mu u = f \text{ in } \Omega, \quad (1.9)$$

where $f \in L^2(\Omega)$ is a given source function and ϵ, μ are the electric permittivity, magnetic permeability respectively. The domain Ω is split into two subdomains, Ω_1, Ω_2 and ϵ has a different sign in the two subdomains. The natural variational formulation corresponding to (1.9) is as follows: Find $u \in H^1(\Omega)$ such that

$$\left(\frac{1}{\epsilon} \nabla u, \nabla v \right)_{L^2(\Omega)} - \omega^2 (\mu u, v)_{L^2(\Omega)} = -(f, v)_{L^2(\Omega)} \text{ for all } v \in H^1(\Omega). \quad (1.10)$$

Due to the sign change of ϵ , the coercivity of (1.10) is not guaranteed. One remedy is to consider dissipative materials, which means the permittivity ϵ has positive imaginary part.

The mathematical and numerical well-posedness of this problem has recently been studied in the literature. It has been shown that introducing a new unknown, which is equal to the gradient of the field u in one of subdomain, a new variational problem formulation is of Fredholm type when the absolute value of the permittivity contrast is large enough [6]. It has also been shown that the natural variational formulation is suitable for a finite element discretization with some contrast condition [7]. Our approach differs in that we simply make the physically reasonable assumption that a small amount of energy dissipation is present in both materials near the metal-dielectric interface.

In Chapter 3, we formulate an equivalent natural variational formulation for TE- and TM-polarization for which the permittivity has the positive imaginary part (energy dissipation) and has the different signs for the real part. The optimal design problem for TM-polarization is also discussed, where we investigate how to construct optimal structures for a prescribed energy transmission spectrum.

1.5 Mathematical preliminaries

In this section, we list some mathematical definitions and theorems that are used throughout this dissertation.

Definition 1 (Weak* Convergence [11]) *Let X be a Banach space, X^* its dual and $\langle \cdot, \cdot \rangle$ the bilinear canonical pairing over $X \times X^*$. We say that, for a sequence $\{x_n^*\}$, and $x^* \in X^*$, x_n^* converges weak* to x^* and we denote*

$$x_n^* \xrightarrow{*} x^* \text{ in } X^*$$

if

$$\langle x_n^*, x \rangle \rightarrow \langle x^*, x \rangle \text{ for every } x \in X.$$

Theorem 2 ([11]) *Let X be a reflexive Banach space, let $K > 0$ and let*

$$\|x_n\| \leq K$$

then there exists $x \in X$ and a subsequence $\{x_{n_j}\}$ of $\{x_n\}$ such that

$$x_{n_j} \rightharpoonup x \text{ in } X.$$

Theorem 3 ([1]) *Let Ω be a bounded domain in \mathbb{R}^n . Then imbedding*

$$W^{1,\infty}(\Omega) \rightarrow L^\infty(\Omega)$$

is compact.

Theorem 4 (Lax-Milgram Theorem [16]) *Let H be a Hilbert space, with norm $\|\cdot\|$ and inner product (\cdot, \cdot) . We let $\langle \cdot, \cdot \rangle$ denote the pairing of H with its dual space. Assume that $B(u, v)$ is a bounded bilinear form over $H \times H$, that is, there exists $\alpha > 0$ such that*

$$|B(u, v)| \leq \alpha \|u\| \|v\| \text{ for all } u, v \in H.$$

And we assume that $B(u, v)$ is coercive on H , that is, there exists $\beta > 0$ such that

$$B(u, u) \geq \beta \|u\|^2.$$

Let $f : H \rightarrow \mathbb{C}$ be a bounded linear functional on H . Then there exists a unique $u \in H$ such that

$$B(u, v) = \langle f, v \rangle \text{ for all } v \in H.$$

Furthermore, there is a bounded linear operator $A : H \rightarrow H$ such that

$$B(u, v) = \langle Au, v \rangle_H \text{ for all } v \in H,$$

and A has a bounded inverse $A^{-1} : H \rightarrow H$ with $\|A^{-1}\| \leq \frac{1}{\beta}$.

Definition 5 (Sobolev space H^s [18]) *If $s \in \mathbb{R}$, the Sobolev space $H^s(\mathbb{T}^n)$, where \mathbb{T}^n is the n -dimensional torus, is defined as the space of all tempered distributions f on \mathbb{T}^n with the property that*

$$[(1 + |n|^2)^{s/2} \hat{f}(n)] \in l^2(\mathbb{Z}^n),$$

where $\hat{f}(n)$ represents the n -th Fourier coefficient of f . We define inner product and norm on H^s by

$$\langle f, g \rangle_{H^s} = \sum_{n \in \mathbb{Z}^n} \hat{f}(n) (1 + |n|^2)^s \overline{\hat{g}(n)},$$

$$\|f\|_{H^s} = \left[\sum_{n \in \mathbb{Z}^n} (1 + |n|^2)^s |\hat{f}(n)|^2 \right]^{1/2}.$$

1.6 Outline

This dissertation is organized as follows. In the first chapter, we investigate electromagnetic wave transmission through periodic hole arrays in an infinitesimally thin electric perfect conductor. Throughout Section 2.1 and Section 2.2, we derive a corresponding mathematical model, obtaining an explicit linear operator equation for the tangential components of the field inside the apertures. The linear operator is regularized to ensure a stable numerical solution. We analyze the solvability of the linear equation with a truncated and mollified operator in Section 2.3. In Section 2.4, we extend our problem to the case of an arbitrary incoming wave by adding a Bloch condition. In Section 2.5, we establish the conservation of energy that states the total energy of the reflected and transmitted waves is equal to the energy of the incident wave. We then introduce some numerical experiments in Section 2.6.

In Chapter 3, we discuss electromagnetic wave propagation through periodic plasmonic structures where dielectric constants have different signs, and work on the design of optimal structures for a prescribed energy. We describe the model in Section 3.1 and then formulate an equivalent variational problem over a bounded region with transparent boundary conditions. In Section 3.2 and Section 3.3, we show that variational problems for TE- and TM-polarization have a unique solution over a range of incidence angles. In Section 3.4, the optimal design problem is introduced. We state the optimal design as a minimization problem and we show that the minimization problem has at least one solution. Some numerical experiments are introduced in Section 3.5.

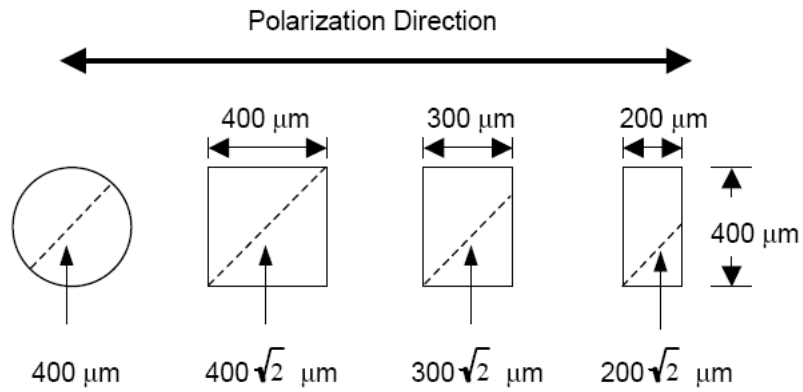

Figure 1.1. Four different aperture shapes. (Figure taken from [9])

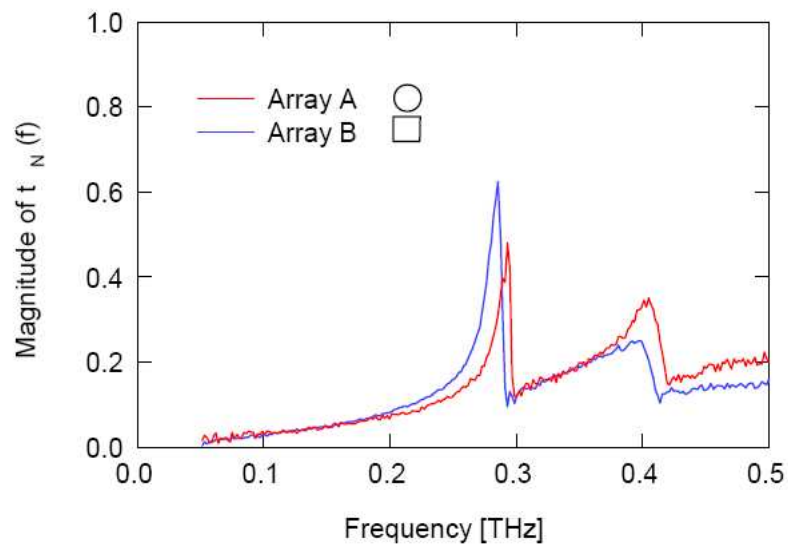

Figure 1.2. Magnitude of the normalized amplitude transmission spectra for Array A and B. (Figure taken from [9])

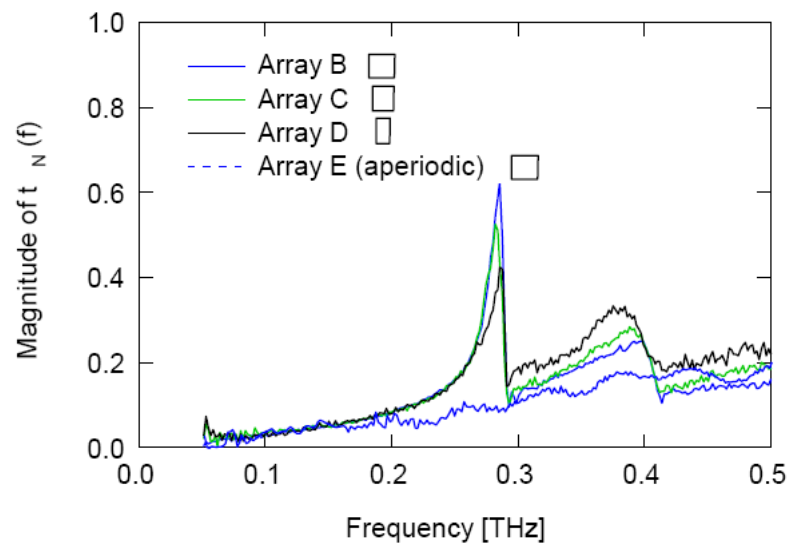

Figure 1.3. Magnitude of the normalized amplitude transmission spectra for Array B-E. (Figure taken from [9])

CHAPTER 2

DIFFRACTION THROUGH A PERIODIC APERTURE ARRAY IN A PERFECT CONDUCTOR

2.1 Model problem

Consider time-harmonic electromagnetic wave propagation (with time dependence $e^{-i\omega t}$) modeled by Maxwell's equations

$$\nabla \times E = i\omega H, \tag{2.1}$$

$$\nabla \times H = -i\omega E, \tag{2.2}$$

$$\nabla \cdot E = 0, \tag{2.3}$$

$$\nabla \cdot H = 0, \tag{2.4}$$

where ω represents the frequency, and we have assumed that the dielectric constant ϵ and the magnetic permeability μ are both identically equal to 1.

Denoting points $x = (x_1, x_2, x_3) \in \mathbb{R}^3$, let $\Gamma = \{x \in \mathbb{R}^3 : x_3 = 0\}$. Define the two half-spaces $\mathbb{R}_+^3 = \{x : x_3 > 0\}$, and $\mathbb{R}_-^3 = \{x : x_3 < 0\}$. The subset $\Omega \subset \Gamma$ will represent holes in a perfect conductor located in the plane $\{x_3 = 0\}$. We assume that Ω is 2π periodic in the x_1, x_2 variables, that is, $x \in \Omega$ if and only if $x + (2\pi n, 2\pi m, 0) \in \Omega$ for all integers m, n . Taking the period to be 2π imposes no loss of generality since any other period can be obtained by rescaling ω . Non-square lattice geometries can be obtained with modifications.

To simplify the discussion, assume that the E, H fields are also 2π periodic in the x_1, x_2 variables. This assumption is valid in case of an incoming plane wave normally incident on Γ . This will be generalized in Section 2.4 by adding a Bloch condition. For the detailed problem geometry, refer to Figure 2.1.

2.2 Problem formulation

Assume that the region $\Gamma - \Omega$ is occupied by an infinitesimally thin “perfect conductor”. The presence of this medium imposes boundary conditions on the electric and magnetic

fields. In particular, the tangential components of E and the normal component of H are both zero on $\Gamma - \Omega$.

Write $E = (u_1, u_2, u_3)$ and $H = (v_1, v_2, v_3)$. Consider first the fields in the half-space $x_3 > 0$. It follows from Maxwell's equations that each field component satisfies the Helmholtz equation $\Delta u_j + \omega^2 u_j = 0$, $j = 1, 2, 3$. Use the periodicity of the field to represent E field in a Fourier series and we impose an outgoing wave condition to represent the scattered E field that propagates in the positive x_3 direction by taking only the positive sign on the coefficient of x_3 . Then it follows from separation of variables that E can be represented

$$E(x) = \sum_{n \in \mathbb{Z}^2} \hat{E}(n) e^{ik_n \cdot x},$$

where $n = (n_1, n_2)$, $k_n = (n_1, n_2, \beta_n)$, and $\beta_n = \sqrt{\omega^2 - n_1^2 - n_2^2}$. From the divergence condition $\nabla \cdot E = 0$, it follows that $ik_n \cdot \hat{E}(n) = 0$ for all n . Denoting $\hat{E}(n) = (\hat{u}_1(n), \hat{u}_2(n), \hat{u}_3(n))$, we can then write

$$\hat{u}_3(n) = -\frac{1}{\beta_n} (n_1 \hat{u}_1(n) + n_2 \hat{u}_2(n)), \quad (2.5)$$

so that u_3 is completely determined by u_1, u_2 . Furthermore, since

$$H = \frac{1}{i\omega} \nabla \times E,$$

we can represent

$$H(x) = \frac{1}{\omega} \sum_{n \in \mathbb{Z}^2} \begin{pmatrix} n_2 \hat{u}_3(n) - \beta_n \hat{u}_2(n) \\ \beta_n \hat{u}_1(n) - n_1 \hat{u}_3(n) \\ n_1 \hat{u}_2(n) - n_2 \hat{u}_1(n) \end{pmatrix} e^{ik_n \cdot x}. \quad (2.6)$$

Assuming for now that E and H are sufficiently regular, let us denote by u_1^+ and u_2^+ the traces of the tangential components of E in the region $\{x_3 > 0\}$, taken on the boundary $\{x_3 = 0\}$, and similarly for v_1^+, v_2^+ . Then $\hat{u}_1(n)$ and $\hat{u}_2(n)$ are exactly the Fourier series coefficients of u_1^+, u_2^+ :

$$\hat{u}_j(n) = \frac{1}{4\pi^2} \int_0^{2\pi} \int_0^{2\pi} u_j^+(x_1, x_2) e^{-i(x_1 n_1 + x_2 n_2)} dx_1 dx_2, \quad j = 1, 2.$$

One can then define a map T such that $T(u_1^+, u_2^+) = (v_1^+, v_2^+)$. In particular, combining (2.5) and (2.6), we have

$$T \begin{pmatrix} u_1^+ \\ u_2^+ \end{pmatrix} (x) \equiv \begin{pmatrix} v_1^+(x) \\ v_2^+(x) \end{pmatrix} = \frac{1}{\omega} \sum_{n \in \mathbb{Z}^2} \begin{pmatrix} -\frac{n_1 n_2}{\beta_n} \hat{u}_1(n) - (\frac{n_2^2}{\beta_n} + \beta_n) \hat{u}_2(n) \\ (\frac{n_1^2}{\beta_n} + \beta_n) \hat{u}_1(n) + \frac{n_1 n_2}{\beta_n} \hat{u}_2(n) \end{pmatrix} e^{in \cdot x}. \quad (2.7)$$

Thus T maps the tangential components of the E field to the tangential components of the H field.

Following a similar derivation in the region $\{x_3 < 0\}$, we find the relationship

$$(v_1^-, v_2^-) = -T(u_1^-, u_2^-),$$

where T is defined exactly as above.

It is perhaps interesting that $T^2 = -I$.

By insisting that the tangential components of the E and H fields are both continuous across the boundary $\{x_3 = 0\}$ across the aperture region Ω , and that the tangential components of E are zero at the perfect conductor $\Gamma - \Omega$, we obtain a complete set of equations. First let us list all the conditions which must be satisfied. We assume that an incident field (E^i, H^i) is coming in from above, with tangential components (u_1^i, u_2^i) and (v_1^i, v_2^i) .

$$(u_1^+, u_2^+) + (u_1^i, u_2^i) = 0 \quad \text{on } \Gamma - \Omega, \quad (2.8)$$

$$(u_1^-, u_2^-) = 0 \quad \text{on } \Gamma - \Omega, \quad (2.9)$$

$$(u_1^+, u_2^+) + (u_1^i, u_2^i) = (u_1^-, u_2^-) \quad \text{on } \Omega, \quad (2.10)$$

$$(v_1^+, v_2^+) + (v_1^i, v_2^i) = (v_1^-, v_2^-) \quad \text{on } \Omega, \quad (2.11)$$

$$T(u_1^+, u_2^+) = (v_1^+, v_2^+) \quad \text{on } \Gamma, \quad (2.12)$$

$$T(u_1^-, u_2^-) = -(v_1^-, v_2^-) \quad \text{on } \Gamma. \quad (2.13)$$

Defining the characteristic function χ of Ω , we see from (2.8) that

$$(u_1^+, u_2^+) = \chi(u_1^+, u_2^+) - (1 - \chi)(u_1^i, u_2^i), \quad \text{on } \Gamma. \quad (2.14)$$

It then follows from (2.12)

$$\chi(v_1^+, v_2^+) = \chi T \chi(u_1^+, u_2^+) - \chi T(1 - \chi)(u_1^i, u_2^i), \quad \text{on } \Gamma.$$

Combining this and (2.14) with (2.11),

$$\chi T \chi(u_1^+, u_2^+) - \chi T(1 - \chi)(u_1^i, u_2^i) = \chi(v_1^-, v_2^-) - \chi(v_1^i, v_2^i).$$

Inserting equalities (2.13), (2.9), and (2.10),

$$\chi T \chi(u_1^+, u_2^+) - \chi T(1 - \chi)(u_1^i, u_2^i) = -\chi T \chi(u_1^-, u_2^-) - \chi(v_1^i, v_2^i)$$

$$= -\chi T\chi(u_1^+, u_2^+) - \chi T\chi(u_1^i, u_2^i) - \chi(v_1^i, v_2^i).$$

Now we rearrange to get the equation

$$2\chi T\chi(u_1^+, u_2^+) = \chi T(u_1^i, u_2^i) - \chi(v_1^i, v_2^i) - 2\chi T\chi(u_1^i, u_2^i). \quad (2.15)$$

Since (u_1^i, u_2^i) and (v_1^i, v_2^i) each satisfy the Helmholtz equation and are traveling downward, we get $T(u_1^i, u_2^i) = -(v_1^i, v_2^i)$. Applying this to the above equation (2.15),

$$\chi T\chi(u_1^+, u_2^+) = -\chi(v_1^i, v_2^i) - \chi T\chi(u_1^i, u_2^i). \quad (2.16)$$

Adding $(1 - \chi)(u_1^+, u_2^+) = -(1 - \chi)(u_1^i, u_2^i)$ from (2.8) to (2.16), we get the single equation

$$(\chi T\chi + (1 - \chi))(u_1^+, u_2^+) = -\chi(v_1^i, v_2^i) - (\chi T\chi + (1 - \chi))(u_1^i, u_2^i) \quad (2.17)$$

for the unknown field components (u_1^+, u_2^+) . Note that once (u_1^+, u_2^+) are determined, the entire electromagnetic field (E, H) is known both above and below Γ . Also note that equation (2.17) automatically holds on $\Gamma - \Omega$, and hence needs to be solved only on the apertures Ω .

2.3 Regularization, existence and uniqueness

For each $n = (n_1, n_2) \in \mathbb{Z}^2$, define the complex-valued 2×2 matrix

$$B_n = \frac{1}{\omega} \begin{pmatrix} -\frac{n_1 n_2}{\beta_n} & -\frac{n_2^2}{\beta_n} - \beta_n \\ \frac{n_1^2}{\beta_n} + \beta_n & \frac{n_1 n_2}{\beta_n} \end{pmatrix},$$

so that

$$(Tu)(x) = \sum_{n \in \mathbb{Z}^2} B_n \hat{u}(n) e^{in \cdot x}, \text{ where } \hat{u}(n) = \begin{pmatrix} \hat{u}_1(n) \\ \hat{u}_2(n) \end{pmatrix}.$$

A simple calculation reveals that the operator norm $\|B_n\|^2 \leq \frac{C|n|^2}{\omega^2}$, where C is a constant. Unfortunately, the matrix norm of B_n is not bounded.

Now we consider the truncated operator

$$(T^N u)(x) = \sum_{|n| < N} B_n \hat{u}(n) e^{in \cdot x} \quad (2.18)$$

It is trivial that $\|B_n\|_{|n| < N}$ is bounded, since $\|B_n\|_{|n| < N}^2 \leq \frac{C|n|^2}{\omega^2} \leq \frac{C \cdot N^2}{\omega^2}$. It follows immediately that $T^N : L^2(\Gamma, \mathbb{C}^2) \rightarrow L^2(\Gamma, \mathbb{C}^2)$ is bounded. In fact by Parseval's identity:

$$\|T^N u\|^2 = (2\pi)^2 \sum_{|n| < N} |B_n \hat{u}(n)|^2 \leq (2\pi)^2 \sum_{|n| < N} \|B_n\|^2 |\hat{u}(n)|^2 \leq \frac{C \cdot N^2}{\omega^2} \|u\|^2,$$

Define $A^N : L^2(\Omega, \mathbb{C}^2) \rightarrow L^2(\Omega, \mathbb{C}^2)$ by $A^N u = \chi T^N \chi u$.

Given a small real parameter $\delta > 0$, we can then define the “regularized” operator $T_\delta^N = T^N + \delta J$, where

$$J = \begin{pmatrix} 0 & -I \\ I & 0 \end{pmatrix},$$

and I is the identity operator on $L^2(\Omega, \mathbb{C})$.

Consider the truncated and regularized operator $A_\delta^N u$, defined by

$$\begin{aligned} A_\delta^N u &= \chi T_\delta^N \chi u \\ &= \chi(T^N + \delta J)\chi u \\ &= A^N u + \chi \delta J \chi u. \end{aligned}$$

Then $A_\delta^N : L^2(\Omega, \mathbb{C}^2) \rightarrow L^2(\Omega, \mathbb{C}^2)$ is bounded since T^N is bounded.

Now we claim that A_δ^N is coercive.

First let us express A^N in block matrix form as

$$A^N = \begin{pmatrix} A_{11}^N & A_{12}^N \\ A_{21}^N & A_{22}^N \end{pmatrix},$$

where each A_{jk}^N operates on scalar $L^2(\Omega)$ functions. Explicitly, following the definition of T ,

$$A_{11}^N f = -\frac{\chi}{\omega} \sum_{|n| < N} \frac{n_1 n_2}{\beta_n} (\hat{\chi} f)(n) e^{in \cdot x}, \quad (2.19)$$

$$A_{12}^N f = -\frac{\chi}{\omega} \sum_{|n| < N} \left(\frac{n_2^2}{\beta_n} + \beta_n \right) (\hat{\chi} f)(n) e^{in \cdot x}, \quad (2.20)$$

$$A_{21}^N f = \frac{\chi}{\omega} \sum_{|n| < N} \left(\frac{n_1^2}{\beta_n} + \beta_n \right) (\hat{\chi} f)(n) e^{in \cdot x}, \quad (2.21)$$

$$A_{22}^N f = \frac{\chi}{\omega} \sum_{|n| < N} \frac{n_1 n_2}{\beta_n} (\hat{\chi} f)(n) e^{in \cdot x}. \quad (2.22)$$

It is perhaps not immediately clear that augmenting A with the operator J is a regularization in any typical sense of the word. Nevertheless, it is not difficult to see that A_δ is “coercive” in the sense described below, and hence has a bounded inverse. Notice that the normal operator

$$\begin{aligned} A_\delta^{N*} A_\delta^N &= A^{N*} A^N + A^{N*} \chi \delta J \chi + \chi \delta J^* \chi A^N + \delta^2 \chi J^* \chi \chi J \chi \\ &= A^{N*} A^N + \delta (A^{N*} J \chi + J^* \chi A^N) + \delta^2 J^* J \chi. \end{aligned}$$

The first term, $A^{N*} A^N$ is necessarily Hermitian positive semidefinite, and $J^* J = \begin{pmatrix} I & 0 \\ 0 & I \end{pmatrix}$.

Thus, if we can show that the operator $A^{N*} J \chi + J^* \chi A^N$ is positive semidefinite, it will follow immediately that $\|A_\delta^N u\|_{L^2(\Omega)} \geq \delta \|u\|_{L^2(\Omega)}$, for all $u \in L^2(\Omega, \mathbb{C}^2)$.

Notice that by definitions (2.19), (2.22), $A_{22}^N = -A_{11}^N$, so

$$A^{N*}J\chi + J^*\chi A^N = \begin{pmatrix} A_{21}^{N*} + A_{21}^N & -A_{11}^{N*} - A_{11}^N \\ -A_{11}^{N*} - A_{11}^N & -A_{12}^{N*} - A_{12}^N \end{pmatrix}.$$

For $\omega \leq 1$, β_n is purely imaginary for all $n \in \mathbb{Z}^2$, and it follows from the definition (2.19) that A_{11}^N is anti-Hermitian, that is, $A_{11}^{N*} + A_{11}^N = 0$. Thus the off-diagonal blocks in the matrix above vanish.

Given $u = (u_1, u_2) \in L^2(\Omega, \mathbb{C}^2)$, we then find that

$$\begin{aligned} & \langle (A^{N*}J\chi + J^*\chi A^N)u, u \rangle_{L^2(\Omega, \mathbb{C}^2)} \\ &= \langle (A_{21}^{N*} + A_{21}^N)u_1, u_1 \rangle_{L^2(\Omega, \mathbb{C})} - \langle (A_{12}^{N*} + A_{12}^N)u_2, u_2 \rangle_{L^2(\Omega, \mathbb{C})}. \end{aligned}$$

Again using the definitions (2.20), (2.21) along with Parseval's identity, we find

$$\langle (A_{21}^{N*} + A_{21}^N)u_1, u_1 \rangle_{L^2(\Omega, \mathbb{C})} = \frac{1}{\pi} \sum_{|n| < N} \operatorname{Re} \left(\frac{n_1^2}{\beta_n} + \beta_n \right) |\hat{\chi}u_1(n)|^2 = 0,$$

and similarly $\langle (A_{12}^{N*} + A_{12}^N)u_2, u_2 \rangle_{L^2(\Omega, \mathbb{C})} = 0$. It follows that

$$\langle A_\delta^{N*} A_\delta^N u, u \rangle_{L^2(\Omega)} \geq \delta^2 \langle u, u \rangle_{L^2(\Omega)},$$

or $\|A_\delta^N u\|_{L^2(\Omega)} \geq \delta \|u\|_{L^2(\Omega)}$, for all u . Summarizing,

Lemma 6 *For $\omega \leq 1$, the regularized operator $A_\delta^N : L^2(\Omega, \mathbb{C}^2) \rightarrow L^2(\Omega, \mathbb{C}^2)$ has a bounded inverse $(A_\delta^N)^{-1}$, with $\|(A_\delta^N)^{-1}\| \leq \frac{1}{\delta}$, for all $\delta > 0$.*

For problems involving optimization of the aperture Ω , it is important to analyze with respect to a fixed reference domain. In order to formulate the problem over the fixed domain Γ , we augment A_δ^N as in (2.17). We now prove that the regularized, truncated operator $\tilde{A}_\delta^N = A_\delta^N + (1 - \chi) : L^2(\Gamma, \mathbb{C}^2) \rightarrow L^2(\Gamma, \mathbb{C}^2)$ is coercive.

$$\begin{aligned} \|\tilde{A}_\delta^N u\|_{L^2(\Gamma)}^2 &= \|A_\delta^N u + (1 - \chi)u\|_{L^2(\Gamma)}^2 \\ &= \langle A_\delta^N u + (1 - \chi)u, A_\delta^N u + (1 - \chi)u \rangle_{L^2(\Gamma)} \\ &= \langle A_\delta^N u, A_\delta^N u \rangle_{L^2(\Gamma)} + \langle A_\delta^N u, (1 - \chi)u \rangle_{L^2(\Gamma)} \\ &\quad + \langle (1 - \chi)u, A_\delta^N u \rangle_{L^2(\Gamma)} + \langle (1 - \chi)u, (1 - \chi)u \rangle_{L^2(\Gamma)}. \end{aligned}$$

Note that $\langle A_\delta^N u, A_\delta^N u \rangle_{L^2(\Gamma)} \geq \delta^2 \langle \chi u, \chi u \rangle_{L^2(\Gamma)}$ and now we assume $\delta < 1$. Then

$$\langle A_\delta^N u, A_\delta^N u \rangle_{L^2(\Gamma)} + \langle (1 - \chi)u, (1 - \chi)u \rangle_{L^2(\Gamma)}$$

$$\begin{aligned}
&\geq \delta^2 \langle \chi u, \chi u \rangle_{L^2(\Gamma)} + \langle (1-\chi)u, (1-\chi)u \rangle_{L^2(\Gamma)} \\
&\geq \delta^2 [\langle \chi u, \chi u \rangle_{L^2(\Gamma)} + \langle (1-\chi)u, (1-\chi)u \rangle_{L^2(\Gamma)}] \\
&= \delta^2 [\langle \chi u, \chi u \rangle_{L^2(\Gamma)} + \langle \chi u, (1-\chi)u \rangle_{L^2(\Gamma)} + \langle (1-\chi)u, \chi u \rangle_{L^2(\Gamma)} \\
&\quad + \langle (1-\chi)u, (1-\chi)u \rangle_{L^2(\Gamma)}] \\
&= \delta^2 \langle \chi u + (1-\chi)u, \chi u + (1-\chi)u \rangle_{L^2(\Gamma)} \\
&= \delta^2 \langle u, u \rangle_{L^2(\Gamma)} \\
&= \delta^2 \|u\|_{L^2(\Gamma)}^2.
\end{aligned}$$

We complete the proof for the coercivity of A_δ^N by showing

$$\langle A_\delta^N u, (1-\chi)u \rangle_{L^2(\Gamma)} + \langle (1-\chi)u, A_\delta^N u \rangle_{L^2(\Gamma)} = 0. \quad (2.23)$$

Using the definition of A_δ^N , we have

$$\begin{aligned}
Q(u) &\equiv \langle A_\delta^N u, (1-\chi)u \rangle + \langle (1-\chi)u, A_\delta^N u \rangle \\
&= \langle \chi \sum_{|n|<N} (B_{11}^n(\widehat{\chi u_1}) + B_{12}^n(\widehat{\chi u_2}))e^{in \cdot x} - \delta \chi^2 u_2, (1-\chi)u_1 \rangle \\
&\quad + \langle \chi \sum_{|n|<N} (B_{21}^n(\widehat{\chi u_1}) + B_{22}^n(\widehat{\chi u_2}))e^{in \cdot x} + \delta \chi^2 u_1, (1-\chi)u_2 \rangle \\
&\quad + \langle (1-\chi)u_1, \chi \sum_{|n|<N} (B_{11}^n(\widehat{\chi u_1}) + B_{12}^n(\widehat{\chi u_2}))e^{in \cdot x} - \delta \chi^2 u_2 \rangle \\
&\quad + \langle (1-\chi)u_2, \chi \sum_{|n|<N} (B_{21}^n(\widehat{\chi u_1}) + B_{22}^n(\widehat{\chi u_2}))e^{in \cdot x} + \delta \chi^2 u_1 \rangle,
\end{aligned}$$

where B_{ij}^n is the (i, j) component of B_n . Simplifying the above,

$$\begin{aligned}
Q(u) &= -\delta \langle \chi^2 u_2, (1-\chi)u_1 \rangle + \delta \langle \chi^2 u_1, (1-\chi)u_2 \rangle \\
&\quad -\delta \langle (1-\chi)u_1, \chi^2 u_2 \rangle + \delta \langle (1-\chi)u_2, \chi^2 u_1 \rangle \\
&\quad + \langle \chi \sum_{|n|<N} (B_{11}^n(\widehat{\chi u_1}) + B_{12}^n(\widehat{\chi u_2}))e^{in \cdot x}, (1-\chi)u_1 \rangle \\
&\quad + \langle \chi \sum_{|n|<N} (B_{21}^n(\widehat{\chi u_1}) + B_{22}^n(\widehat{\chi u_2}))e^{in \cdot x}, (1-\chi)u_2 \rangle \\
&\quad + \langle (1-\chi)u_1, \chi \sum_{|n|<N} (B_{11}^n(\widehat{\chi u_1}) + B_{12}^n(\widehat{\chi u_2}))e^{in \cdot x} \rangle \\
&\quad + \langle (1-\chi)u_2, \chi \sum_{|n|<N} (B_{21}^n(\widehat{\chi u_1}) + B_{22}^n(\widehat{\chi u_2}))e^{in \cdot x} \rangle.
\end{aligned}$$

Note that the first four terms cancel. Simplifying and rearranging the above,

$$Q(u) = \langle \chi \sum_{|n|<N} B_{11}^n(\widehat{\chi u_1})e^{in \cdot x}, (1-\chi)u_1 \rangle + \langle (1-\chi)u_1, \chi \sum_{|n|<N} B_{11}^n(\widehat{\chi u_1})e^{in \cdot x} \rangle$$

$$\begin{aligned}
& + \langle \chi \sum_{|n| < N} B_{12}^n(\widehat{\chi u_2}) e^{in \cdot x}, (1 - \chi)u_1 \rangle + \langle (1 - \chi)u_1, \chi \sum_{|n| < N} B_{12}^n(\widehat{\chi u_2}) e^{in \cdot x} \rangle \\
& + \langle \chi \sum_{|n| < N} B_{21}^n(\widehat{\chi u_1}) e^{in \cdot x}, (1 - \chi)u_2 \rangle + \langle (1 - \chi)u_2, \chi \sum_{|n| < N} B_{21}^n(\widehat{\chi u_1}) e^{in \cdot x} \rangle \\
& + \langle \chi \sum_{|n| < N} B_{22}^n(\widehat{\chi u_2}) e^{in \cdot x}, (1 - \chi)u_2 \rangle + \langle (1 - \chi)u_2, \chi \sum_{|n| < N} B_{22}^n(\widehat{\chi u_2}) e^{in \cdot x} \rangle.
\end{aligned}$$

Substituting each component of B_n into above and simplifying,

$$\begin{aligned}
Q(u) &= \frac{1}{\omega} \sum_{|n| < N} \frac{n_1 n_2}{\beta_n} (\widehat{\chi u_1} \overline{\widehat{\chi^2 u_1}} - \overline{\widehat{\chi u_1}} \widehat{\chi^2 u_1}) \\
&+ \frac{1}{\omega} \sum_{|n| < N} \left(\frac{n_2^2}{\beta_n} + \beta_n \right) (\overline{\widehat{\chi u_2}} \chi(1 - \chi)u_1 - \widehat{\chi u_2} \overline{\chi(1 - \chi)u_1}) \\
&+ \frac{1}{\omega} \sum_{|n| < N} \left(\frac{n_1^2}{\beta_n} + \beta_n \right) (\widehat{\chi u_1} \overline{\chi(1 - \chi)u_2} - \overline{\widehat{\chi u_1}} \chi(1 - \chi)u_2) \\
&+ \frac{1}{\omega} \sum_{|n| < N} \frac{n_1 n_2}{\beta_n} (\overline{\widehat{\chi u_2}} \widehat{\chi^2 u_2} - \widehat{\chi u_2} \overline{\widehat{\chi^2 u_2}}).
\end{aligned} \tag{2.24}$$

Looking at the first line of the above, we split the summation into the positive part and the negative part on n . Then

$$\begin{aligned}
& \frac{1}{\omega} \sum_{|n| < N} \frac{n_1 n_2}{\beta_n} (\widehat{\chi u_1} \overline{\widehat{\chi^2 u_1}} - \overline{\widehat{\chi u_1}} \widehat{\chi^2 u_1}) \\
&= \frac{1}{\omega} \sum_{0 < n < N} \frac{n_1 n_2}{\beta_n} [(\widehat{\chi u_1})(n) \overline{(\widehat{\chi^2 u_1})(n)} - \overline{(\widehat{\chi u_1})(n)} (\widehat{\chi^2 u_1})(n)] \\
&\quad + (\widehat{\chi u_1})(-n) \overline{(\widehat{\chi^2 u_1})(-n)} - \overline{(\widehat{\chi u_1})(-n)} (\widehat{\chi^2 u_1})(-n)] \\
&= \frac{1}{\omega} \sum_{0 < n < N} \frac{n_1 n_2}{\beta_n} [(\overline{\widehat{\chi u_1}})(-n) \overline{(\widehat{\chi^2 u_1})(-n)} - \overline{(\overline{\widehat{\chi u_1}})(-n)} \widehat{(\chi^2 u_1)}(-n)] \\
&\quad + (\widehat{\chi u_1})(-n) \overline{(\widehat{\chi^2 u_1})(-n)} - \overline{(\widehat{\chi u_1})(-n)} (\widehat{\chi^2 u_1})(-n)] \\
&= \frac{1}{\omega} \sum_{0 < n < N} \frac{n_1 n_2}{\beta_n} [(\overline{\widehat{\chi u_1}})(-n) \overline{(\widehat{\chi^2 u_1})(-n)} - (\widehat{\chi u_1})(-n) \widehat{(\chi^2 u_1)}(-n)] \\
&\quad + (\widehat{\chi u_1})(-n) \overline{(\widehat{\chi^2 u_1})(-n)} - \overline{(\widehat{\chi u_1})(-n)} (\widehat{\chi^2 u_1})(-n)] \\
&= 0.
\end{aligned}$$

Applying a similar calculation to the other three lines (2.24)-(2.25), we get (2.23). It follows that $\|\tilde{A}_\delta^N u\|_{L^2(\Gamma)} \geq \delta \|u\|_{L^2(\Gamma)}$, for all u . Summarizing,

Lemma 7 *For $\omega \leq 1$, the regularized, truncated operator $\tilde{A}_\delta^N : L^2(\Gamma, \mathbb{C}^2) \rightarrow L^2(\Gamma, \mathbb{C}^2)$ has a bounded inverse $(\tilde{A}_\delta^N)^{-1}$, with $\|(\tilde{A}_\delta^N)^{-1}\| \leq \frac{1}{\delta}$, for all $\delta > 0$.*

Denoting the right-hand side in (2.17) by f , it follows that the regularized, truncated problem

$$\tilde{A}_\delta^N u = f, \quad \text{in } L^2(\Gamma). \quad (2.25)$$

has a unique solution $u^N \in L^2(\Gamma, \mathbb{C}^2)$, with $\|u^N\| \leq \frac{1}{\delta} \|f\|$.

We consider the mollified operator $\tilde{A}_{\delta,\beta} = \chi_\beta(T + \delta J)\chi_\beta + (1 - \chi_\beta) : H^{-\epsilon}(\Gamma, \mathbb{C}^2) \rightarrow H^{-\epsilon-1}(\Gamma, \mathbb{C}^2)$ for any $\epsilon > 0$, where $\chi_\beta \in C^\infty(\Gamma)$ is a smooth version of χ , obtained by mollification with a β -radius approximation to the identity. We prove the existence of the solution of the regularized problem $\tilde{A}_{\delta,\beta} u = f$.

Holding δ, β fixed, since $\{u^N\}$ is bounded in $L^2(\Gamma, \mathbb{C}^2)$, there exists a subsequence $\{u^N\}$ (using the same notation) such that $\{u^N\}$ converges weakly to u in $L^2(\Gamma, \mathbb{C}^2)$ for some u as $N \rightarrow \infty$. This implies by Parseval's theorem that $\{\hat{u}^N\}$ converges weakly to \hat{u} in $L^2(\mathbb{Z}^2)$ as $N \rightarrow \infty$. Since the imbedding $L^2(\Gamma) \rightarrow H^{-\epsilon}(\Gamma)$ is compact, it immediately follows that u^N converges strongly to u in $H^{-\epsilon}$, where $\epsilon > 0$ as $N \rightarrow \infty$. To show the existence of the solution of the regularized problem $\tilde{A}_{\delta,\beta} u = f$, we prove that $\tilde{A}_{\delta,\beta}^N u^N$ converges to $\tilde{A}_{\delta,\beta} u$ in $H^{-\epsilon-1}(\Gamma)$ as $N \rightarrow \infty$.

$$\begin{aligned} & \|\tilde{A}_{\delta,\beta}^N u^N - \tilde{A}_{\delta,\beta} u\|_{H^{-\epsilon-1}(\Gamma)} \\ & \leq \|\chi_\beta(T^N + \delta J)\chi_\beta u^N + (1 - \chi_\beta)u^N - \chi_\beta(T + \delta J)\chi_\beta u - (1 - \chi_\beta)u\|_{H^{-\epsilon-1}(\Gamma)} \\ & \leq \|\chi_\beta T^N \chi_\beta u^N - \chi_\beta T \chi_\beta u\|_{H^{-\epsilon-1}(\Gamma)} + \|(\chi_\beta \delta J \chi_\beta + (1 - \chi_\beta))(u^N - u)\|_{H^{-\epsilon-1}(\Gamma)}. \end{aligned}$$

The second term goes to zero since $\|u^N - u\|_{H^{-\epsilon}(\Gamma)} \rightarrow 0$ as $N \rightarrow \infty$. Looking at the first term of the above,

$$\begin{aligned} & \|\chi_\beta T^N \chi_\beta u^N - \chi_\beta T \chi_\beta u\|_{H^{-\epsilon-1}(\Gamma)} \\ & \leq \|\chi_\beta T^N \chi_\beta u^N - \chi_\beta T \chi_\beta u^N\|_{H^{-\epsilon-1}(\Gamma)} + \|\chi_\beta T \chi_\beta u^N - \chi_\beta T \chi_\beta u\|_{H^{-\epsilon-1}(\Gamma)}. \end{aligned}$$

Due to the following two results

$$\begin{aligned} & \|\chi_\beta T^N \chi_\beta u^N - \chi_\beta T \chi_\beta u^N\|_{H^{-\epsilon-1}(\Gamma)}^2 \\ & = \|\chi_\beta \sum_{|n|>N} \widehat{B_n \chi_\beta u^N} e^{in \cdot x}\|_{H^{-\epsilon-1}(\Gamma)}^2 \\ & = \sum_{|n|>N} |\widehat{B_n \chi_\beta u^N}|^2 (1 + |n|^2)^{-\epsilon-1} |\widehat{\chi_\beta e^{in \cdot x}}|^2 \rightarrow 0, \quad N \rightarrow \infty \end{aligned}$$

and

$$\|\chi_\beta T \chi_\beta u^N - \chi_\beta T \chi_\beta u\|_{H^{-\epsilon-1}(\Gamma)} \leq \|\chi_\beta T \chi_\beta\| \|u^N - u\|_{H^{-\epsilon}(\Gamma)} \rightarrow 0, \quad N \rightarrow \infty,$$

the first term also goes to zero. Therefore, we get

$\|A_{\delta,\beta}^{\tilde{N}}u^N - A_{\delta,\beta}^{\tilde{N}}u\|_{H^{-\epsilon-1}(\Gamma)} \rightarrow 0$ as $N \rightarrow \infty$. Summarizing,

Theorem 8 For $\omega \leq 1$ and $\delta, \beta > 0$, and the regularized, mollified operator $A_{\delta,\beta}^{\tilde{N}} = \chi_\beta(T + \delta J)\chi_\beta + (1 - \chi_\beta) : H^{-\epsilon}(\Gamma, \mathbb{C}^2) \rightarrow H^{-\epsilon-1}(\Gamma, \mathbb{C}^2)$, the regularized problem $A_{\delta,\beta}^{\tilde{N}}u = f$ admits a solution in $H^{-\epsilon}(\Gamma, \mathbb{C}^2)$ for any $\epsilon > 0$.

For $\omega > 1$, everything above remains true, except that A_{11} is no longer necessarily anti-Hermitian. Nevertheless, A_{11} can always be expressed as the sum of an anti-Hermitian operator with a compact (finite-rank) operator. Existence and uniqueness of the regularized problem follows for all but a discrete set of parameters. We suspect that it is this finite-rank perturbation that leads to the interesting spectral behavior of the problem.

2.4 Extension to arbitrary incoming wave

We now extend our model to the general case with an arbitrary incoming wave, using the Bloch theorem [3, 23].

Given the incidence vector $K = (k_1, k_2, k_3)$, let $k = (k_1, k_2, 0)$ and define

$$E_k(x) = e^{ik \cdot x} u_k(x), \quad H_k(x) = e^{ik \cdot x} v_k(x),$$

where $u_k(x)$ and $v_k(x)$ are 2π periodic in $x \in \mathbb{R}^3$, that is, for $n = (n_1, n_2, 0)$ where $(n_1, n_2) \in \mathbb{Z}^2$,

$$u_k(x + 2\pi n) = u_k(x), \quad v_k(x + 2\pi n) = v_k(x).$$

Then Maxwell equations can be rewritten as follows.

$$\nabla \times u_k + ik \times u_k = i\omega v_k, \tag{2.26}$$

$$\nabla \times v_k + ik \times v_k = -i\omega u_k, \tag{2.27}$$

$$\nabla \cdot u_k + ik \cdot u_k = 0, \tag{2.28}$$

$$\nabla \cdot v_k + ik \cdot v_k = 0. \tag{2.29}$$

Combining the first two equations, we get

$$(\nabla + ik) \times (\nabla + ik) \times u_k = \omega^2 u_k. \tag{2.30}$$

Let

$$u_k(x) = \sum_{n \in \mathbb{Z}^2} \hat{u}_k(n) e^{ik_n \cdot x}, \tag{2.31}$$

where $k_n = (n_1, n_2, \beta_n)$ and $\beta_n(k) = \sqrt{\omega^2 - (n_1 + k_1)^2 - (n_2 + k_2)^2}$. Then we can check that $u_k(x)$ is a solution of the equation (2.30).

From $\nabla \cdot u_k + ik \cdot u_k = 0$, denoting $\hat{u}_k(n) = (\hat{u}_{k1}(n), \hat{u}_{k2}(n), \hat{u}_{k3}(n))$, we can get

$$\hat{u}_{k3}(n) = -\frac{1}{\beta_n}((n_1 + k_1)\hat{u}_{k1}(n) + (n_2 + k_2)\hat{u}_{k2}(n)). \quad (2.32)$$

Furthermore, since

$$v_k(x) = \frac{1}{i\omega}(\nabla \times u_k(x) + ik \times u_k(x)), \quad (2.33)$$

$$v_k(x) = \frac{1}{\omega} \sum_{n \in \mathbb{Z}^2} \begin{pmatrix} (n_2 + k_2)\hat{u}_{k3}(n) - \beta_n \hat{u}_{k2}(n) \\ \beta_n \hat{u}_{k1}(n) - (n_1 + k_1)\hat{u}_{k3}(n) \\ (n_1 + k_1)\hat{u}_{k2}(n) - (n_2 + k_2)\hat{u}_{k1}(n) \end{pmatrix} e^{ikn \cdot x}. \quad (2.34)$$

Let us denote by u_{k1}^+ and u_{k2}^+ the traces of the tangential components of u_{k1} and u_{k2} in the region $\{x_3 > 0\}$, taken on the boundary $\{x_3 = 0\}$, and similarly for v_{k1}^+ , v_{k2}^+ . Then $\hat{u}_{k1}(n)$ and $\hat{u}_{k2}(n)$ are exactly the Fourier series coefficients of u_{k1}^+ , u_{k2}^+ :

$$\hat{u}_{kj}(n) = \frac{1}{4\pi^2} \int_0^{2\pi} \int_0^{2\pi} u_{kj}^+(x_1, x_2) e^{-i(x_1 n_1 + x_2 n_2)} dx_1 dx_2, \quad j = 1, 2.$$

One can then define a map T_k such that $T(u_{k1}^+, u_{k2}^+) = (v_{k1}^+, v_{k2}^+)$. In particular, combining (2.32) and (2.34), we have

$$\begin{aligned} T_k \begin{pmatrix} u_{k1}^+ \\ u_{k2}^+ \end{pmatrix} (x) &\equiv \begin{pmatrix} v_{k1}^+(x) \\ v_{k2}^+(x) \end{pmatrix} \\ &= \frac{1}{\omega} \sum_{n \in \mathbb{Z}^2} \begin{pmatrix} -\frac{(n_1+k_1)(n_2+k_2)}{\beta_n} \hat{u}_{k1}(n) - \left(\frac{(n_2+k_2)^2}{\beta_n} + \beta_n\right) \hat{u}_{k2}(n) \\ \left(\frac{(n_1+k_1)^2}{\beta_n} + \beta_n\right) \hat{u}_{k1}(n) + \frac{(n_1+k_1)(n_2+k_2)}{\beta_n} \hat{u}_{k2}(n) \end{pmatrix} e^{in \cdot x}. \end{aligned}$$

Following a similar derivation in the region $\{x_3 < 0\}$, we find the relationship

$$(v_{k1}^-, v_{k2}^-) = -T_k(u_{k1}^-, u_{k2}^-).$$

Note that the operator T_k can be obtained from the operator T for the case of normally incident waves, by replacing only n_1 and n_2 with $n_1 + k_1$ and $n_2 + k_2$, respectively. Furthermore, (u_{k1}^+, u_{k2}^+) and (v_{k1}^+, v_{k2}^+) have the same boundary conditions as E and H on Γ . So it leads to the same equation as (2.15), (2.16) or (2.17), that is, (u_{k1}^+, u_{k2}^+) satisfies the following equations.

$$2\chi T_k \chi(u_{k1}^+, u_{k2}^+) = \chi T_k(u_{k1}^i, u_{k2}^i) - \chi(v_{k1}^i, v_{k2}^i) - 2\chi T_k \chi(u_{k1}^i, u_{k2}^i), \quad (2.35)$$

$$\chi T_k \chi(u_{k1}^+, u_{k2}^+) = -\chi(v_{k1}^i, v_{k2}^i) - \chi T_k \chi(u_{k1}^i, u_{k2}^i), \quad (2.36)$$

or

$$(\chi T_k \chi + (1 - \chi))(u_{k1}^+, u_{k2}^+) = -\chi(v_{k1}^i, v_{k2}^i) - (\chi T_k \chi + (1 - \chi))(u_{k1}^i, u_{k2}^i). \quad (2.37)$$

Note that once (u_{k1}^+, u_{k2}^+) is determined, the entire electromagnetic field (E, H) is known both above and below Γ , by multiplying by $e^{ik \cdot x}$. For the existence of the solution of the

above equations, we can get the same results as in Lemma 6, Lemma 7 and Theorem 8 for the case of the normally incident wave for a given wave vector k since the incident vector k sitting on T_k does not affect the estimates.

2.5 Conservation of energy

2.5.1 Conservation of energy for an unregularized operator

In this section we show that the electric field through a periodic hole array satisfies the conservation law of energy in the sense that the energy radiated away the perfect conducting screen Γ is the same as that of the incident wave. Consider the following domains : for $b > 0$

$$\begin{aligned} D^+ &= \{x = (x_1, x_2, x_3) \in \mathbb{R}^3 | 0 \leq x_1, x_2 \leq 2\pi, 0 < x_3 < b\}, \\ D^- &= \{x = (x_1, x_2, x_3) \in \mathbb{R}^3 | 0 \leq x_1, x_2 \leq 2\pi, -b < x_3 < 0\}, \end{aligned}$$

along with the boundaries

$$\begin{aligned} \Gamma^+ &= \{x = (x_1, x_2, x_3) \in \mathbb{R}^3 | 0 \leq x_1, x_2 \leq 2\pi, x_3 = b\}, \\ \Gamma &= \{x = (x_1, x_2, x_3) \in \mathbb{R}^3 | 0 \leq x_1, x_2 \leq 2\pi, x_3 = 0\}, \\ \Gamma^- &= \{x = (x_1, x_2, x_3) \in \mathbb{R}^3 | 0 \leq x_1, x_2 \leq 2\pi, x_3 = -b\}. \end{aligned}$$

The problem geometry is described in Figure 2.2.

Let u_j^+ and u_j^- be the j -th component of the electric field E in the domain D^+ , D^- respectively, which means u_j^+ and u_j^- are the j -th component of the reflected wave and of the transmitted wave respectively for $j = 1, 2, 3$. And let u_j^i be the j -th component of the incident wave for $j = 1, 2, 3$. Then u_j^i , u_j^+ and u_j^- satisfy the Helmholtz equation on D^+ and D^- respectively, that is,

$$\Delta u_j^{i+} + \omega^2 u_j^{i+} = 0 \quad \text{on } D^+, \quad (2.38)$$

$$\Delta u_j^- + \omega^2 u_j^- = 0 \quad \text{on } D^-, \quad (2.39)$$

where $u_j^{i+} = u_j^i + u_j^+$ for $j = 1, 2, 3$. Using the periodicity of the field and imposing an outgoing wave condition, u_j^+ and u_j^- can be represented

$$u_j^+(x) = \sum_{n \in \mathbb{Z}^2} \hat{u}_j^+(n) e^{ik_n \cdot x} \quad (2.40)$$

$$u_j^-(x) = \sum_{n \in \mathbb{Z}^2} \hat{u}_j^-(n) e^{il_n \cdot x}, \quad (2.41)$$

where $k_n = (n_1, n_2, \beta_n)$, $l_n = (n_1, n_2, -\beta_n)$ and $\beta_n = \sqrt{\omega^2 - n_1^2 - n_2^2}$.

From the divergence condition $\nabla \cdot E = 0$, it follows that for all n ,

$$\hat{u}_3^+ = -\frac{1}{\beta_n}(n_1\hat{u}_1^+ + n_2\hat{u}_2^+) \quad (2.42)$$

$$\hat{u}_3^- = \frac{1}{\beta_n}(n_1\hat{u}_1^- + n_2\hat{u}_2^-) \quad (2.43)$$

Assume that the incident wave $u^i(x)$ is given

$$u^i(x) = (1, 0, 0)e^{-i\omega x_3}. \quad (2.44)$$

For finite frequency $\omega > 0$, β_n is real for at most finitely many n and then there are only a finite number of propagating waves. In case that β_n is imaginary, the corresponding waves decay exponentially as $|x_3| \rightarrow \infty$. Those damped waves are called evanescent waves. Thus, the reflected and the transmitted energies can be defined as

$$r = \sum_{j=1}^3 \sum_{n^2 \leq \omega^2} \frac{\beta_n}{\omega} |u_j^+(n)|^2$$

and

$$t = \sum_{j=1}^3 \sum_{n^2 \leq \omega^2} \frac{\beta_n}{\omega} |u_j^-(n)|^2,$$

respectively. Note that only propagating modes with β_n real are considered for the energy. For the conservation of energy, we now prove that

$$\sum_{j=1}^3 \sum_{n^2 \leq \omega^2} \frac{\beta_n}{\omega} |u_j^+(n)|^2 + \sum_{j=1}^3 \sum_{n^2 \leq \omega^2} \frac{\beta_n}{\omega} |u_j^-(n)|^2 = 1. \quad (2.45)$$

Denoting by u_1^+ and u_2^+ the traces of the tangential components of E in the region $\{x_3 > 0\}$, taken on the boundary $\{x_3 = 0\}$, and similarly for v_1^+ , v_2^+ , we recall the definition (2.7) of the operator T that maps the tangential components of E field to the tangential components of H field on the boundary $\{x_3 = 0\}$.

Also recall that a similar derivation in the region $\{x_3 < 0\}$ can be made:

$$(v_1^-, v_2^-) = -T(u_1^-, u_2^-). \quad (2.46)$$

For the incident field,

$$(v_1^i, v_2^i) = -T(u_1^i, u_2^i), \quad (2.47)$$

where (u_1^i, u_2^i) and (v_1^i, v_2^i) are tangential components of the incident field E^i and H^i , respectively. We now split and rewrite the operator T as (T_1, T_2) where

$$v_1^+ = T_1(u_1^+, u_2^+) \quad (2.48)$$

$$= \frac{1}{\omega} \sum_{n \in \mathbb{Z}^2} \left(-\frac{n_1 n_2}{\beta_n} \hat{u}_1(n) - \left(\frac{n_2^2}{\beta_n} + \beta_n \right) \hat{u}_2(n) \right) e^{in \cdot x} \quad (2.49)$$

$$v_2^+ = T_2(u_1^+, u_2^+) \quad (2.50)$$

$$= \frac{1}{\omega} \sum_{n \in \mathbb{Z}^2} \left(\left(\frac{n_1^2}{\beta_n} + \beta_n \right) \hat{u}_1(n) + \frac{n_1 n_2}{\beta_n} \hat{u}_2(n) \right) e^{in \cdot x}. \quad (2.51)$$

And

$$v_1^- = -T_1(u_1^-, u_2^-) \quad (2.52)$$

$$v_2^- = -T_2(u_1^-, u_2^-) \quad (2.53)$$

$$v_2^i = -T_2(u_1^i, u_2^i) \quad (2.54)$$

Since

$$H = \frac{1}{i\omega} \nabla \times E, \quad (2.55)$$

$$\begin{aligned} v_1^+ &= \frac{1}{i\omega} \left(\frac{\partial u_3^+}{\partial x_2} - \frac{\partial u_2^+}{\partial x_3} \right), v_2^+ = \frac{1}{i\omega} \left(\frac{\partial u_1^+}{\partial x_3} - \frac{\partial u_3^+}{\partial x_1} \right), \\ v_1^- &= \frac{1}{i\omega} \left(\frac{\partial u_3^-}{\partial x_2} - \frac{\partial u_2^-}{\partial x_3} \right), v_2^- = \frac{1}{i\omega} \left(\frac{\partial u_1^-}{\partial x_3} - \frac{\partial u_3^-}{\partial x_1} \right), \\ v_2^i &= \frac{1}{i\omega} \left(\frac{\partial u_1^i}{\partial x_3} - \frac{\partial u_3^i}{\partial x_1} \right). \end{aligned} \quad (2.56)$$

Combining with (2.48), (2.50), (2.52), (2.53) and (2.54) and rearranging, we get

$$\frac{1}{i\omega} \frac{\partial u_2^+}{\partial x_3} = \frac{1}{i\omega} \frac{\partial u_3^+}{\partial x_2} - T_1(u_1^+, u_2^+) \quad (2.57)$$

$$= \frac{1}{i\omega} \frac{\partial u_2^+}{\partial x_3} - v_1^+ \quad (2.58)$$

and

$$\frac{1}{i\omega} \frac{\partial u_1^+}{\partial x_3} = \frac{1}{i\omega} \frac{\partial u_3^+}{\partial x_1} + T_2(u_1^+, u_2^+) \quad (2.59)$$

$$= \frac{1}{i\omega} \frac{\partial u_3^+}{\partial x_1} + v_2^+. \quad (2.60)$$

Similarly,

$$\frac{1}{i\omega} \frac{\partial u_2^-}{\partial x_3} = \frac{1}{i\omega} \frac{\partial u_3^-}{\partial x_2} + T_1(u_1^-, u_2^-) \quad (2.61)$$

$$= \frac{1}{i\omega} \frac{\partial u_3^-}{\partial x_2} - v_1^-, \quad (2.62)$$

$$\frac{1}{i\omega} \frac{\partial u_1^-}{\partial x_3} = \frac{1}{i\omega} \frac{\partial u_3^-}{\partial x_1} - T_2(u_1^-, u_2^-) \quad (2.63)$$

$$= \frac{1}{i\omega} \frac{\partial u_3^-}{\partial x_1} + v_2^-, \quad (2.64)$$

and

$$\frac{1}{i\omega} \frac{\partial u_1^i}{\partial x_3} = -T_2(u_1^i, u_2^i) = v_2^i. \quad (2.65)$$

Taking the inner product on (2.38) with u_1^{i+} over D^+ , applying integration by parts, and using the equation (2.38),

$$\begin{aligned} & \int_{D^+} (\Delta u_1^{i+} + \omega^2 u_1^{i+}) \overline{u_1^{i+}} dV \\ &= \int_{D^+} \Delta u_1^{i+} \overline{u_1^{i+}} dV + \omega^2 \int_{D^+} |u_1^{i+}|^2 dV \\ &= \int_{\partial D^+} \nabla u_1^{i+} \overline{u_1^{i+}} n dS - \int_{D^+} \nabla u_1^{i+} \nabla \overline{u_1^{i+}} dV + \omega^2 \int_{D^+} |u_1^{i+}|^2 dV \\ &= \int_{\partial D^+} \nabla u_1^{i+} \overline{u_1^{i+}} n dS - \left(\int_{\partial D^+} u_1^{i+} \nabla \overline{u_1^{i+}} n dS - \int_{D^+} u_1^{i+} \Delta \overline{u_1^{i+}} dV \right) \\ &\quad + \omega^2 \int_{D^+} |u_1^{i+}|^2 dV \\ &= \int_{\partial D^+} \nabla u_1^{i+} \overline{u_1^{i+}} n dS - \left(\int_{\partial D^+} u_1^{i+} \nabla \overline{u_1^{i+}} n dS - \int_{D^+} u_1^{i+} (-\omega^2 \overline{u_1^{i+}}) dV \right) \\ &\quad + \omega^2 \int_{D^+} |u_1^{i+}|^2 dV \\ &= \int_{\partial D^+} \nabla u_1^{i+} \overline{u_1^{i+}} n dS - \int_{\partial D^+} u_1^{i+} \nabla \overline{u_1^{i+}} n dS \\ &= \int_{\Gamma^+} \left(\nabla u_1^{i+} \overline{u_1^{i+}} n - u_1^{i+} \nabla \overline{u_1^{i+}} n \right) dS + \int_{\Gamma} \left(u_1^{i+} \nabla \overline{u_1^{i+}} n - \nabla u_1^{i+} \overline{u_1^{i+}} n \right) dS \\ &= \int_{\Gamma^+} \left(\overline{u_1^{i+}} \frac{\partial u_1^{i+}}{\partial x_3} - u_1^{i+} \frac{\partial \overline{u_1^{i+}}}{\partial x_3} \right) dx + \int_{\Gamma} \left(u_1^{i+} \frac{\partial \overline{u_1^{i+}}}{\partial x_3} - \overline{u_1^{i+}} \frac{\partial u_1^{i+}}{\partial x_3} \right) dx, \end{aligned}$$

where n is a normal unit vector in $+x_3$ direction, $n = (0, 0, 1)$. Using (2.40), (2.44) and

$$\begin{aligned} \frac{\partial u_1^{i+}}{\partial x_3} &= -i\omega e^{-i\omega x_3} + \sum_{n \in \mathbb{Z}^2} i\beta_n \hat{u}_1^+(n) e^{ik_n \cdot x} \\ \frac{\partial \overline{u_1^{i+}}}{\partial x_3} &= i\omega e^{i\omega x_3} - \sum_{n \in \mathbb{Z}^2} i\overline{\beta_n} \overline{\hat{u}_1^+(n)} e^{-i\overline{k_n} \cdot x}, \end{aligned}$$

we find that

$$\begin{aligned} & \int_{\Gamma^+} \left(\overline{u_1^{i+}} \frac{\partial u_1^{i+}}{\partial x_3} - u_1^{i+} \frac{\partial \overline{u_1^{i+}}}{\partial x_3} \right) dx \\ &= \int_{\Gamma^+} \left((e^{i\omega x_3} + \sum_{n \in \mathbb{Z}^2} \overline{\hat{u}_1^+(n)} e^{-i\overline{k_n} \cdot x}) (-i\omega e^{-i\omega x_3} + \sum_{n \in \mathbb{Z}^2} i\beta_n \hat{u}_1^+(n) e^{ik_n \cdot x}) \right) dx \end{aligned}$$

$$\begin{aligned}
& -(e^{-i\omega x_3} + \sum_{n \in \mathbb{Z}^2} \hat{u}_1^+(n) e^{ik_n \cdot x}) (i\omega e^{i\omega x_3} - \sum_{n \in \mathbb{Z}^2} \overline{i\beta_n \hat{u}_1^+(n)} e^{-i\overline{k_n} \cdot x}) dx \\
= & \int_{\Gamma^+} (-i\omega + \sum_{n \in \mathbb{Z}^2} i\beta_n \hat{u}_1^+(n) e^{ik_n \cdot x} e^{i\omega x_3} - i\omega \sum_{n \in \mathbb{Z}^2} \overline{\hat{u}_1^+(n)} e^{-i\overline{k_n} \cdot x} e^{-i\omega x_3} \\
& + \sum_{n \in \mathbb{Z}^2} \overline{\hat{u}_1^+(n)} e^{-i\overline{k_n} \cdot x} \sum_{m \in \mathbb{Z}^2} i\beta_m \hat{u}_1^+(m) e^{ik_m \cdot x} - i\omega + \sum_{n \in \mathbb{Z}^2} i\beta_n \overline{\hat{u}_1^+(n)} e^{-i\overline{k_n} \cdot x} e^{-i\omega x_3} \\
& - i\omega \sum_{n \in \mathbb{Z}^2} \hat{u}_1^+(n) e^{ik_n \cdot x} e^{i\omega x_3} + \sum_{n \in \mathbb{Z}^2} \hat{u}_1^+(n) e^{ik_n \cdot x} \sum_{m \in \mathbb{Z}^2} \overline{i\beta_m \hat{u}_1^+(m)} e^{-i\overline{k_m} \cdot x}) dx \\
= & -4\pi^2 i\omega + 4\pi^2 i\omega \hat{u}_1^+(0) e^{2i\omega b} - 4\pi^2 i\omega \overline{\hat{u}_1^+(0)} e^{-2i\omega b} + 4\pi^2 \sum_{n \in \mathbb{Z}^2} i\beta_n |\hat{u}_1^+(n)|^2 e^{i(\beta_n - \overline{\beta_n})b} \\
& -4\pi^2 i\omega + 4\pi^2 i\omega \overline{\hat{u}_1^+(0)} e^{-2i\omega b} - 4\pi^2 i\omega \hat{u}_1^+(0) e^{2i\omega b} + 4\pi^2 \sum_{n \in \mathbb{Z}^2} i\overline{\beta_n} |\hat{u}_1^+(n)|^2 e^{i(\beta_n - \overline{\beta_n})b} \\
= & -8\pi^2 i\omega + 4\pi^2 \sum_{n \in \mathbb{Z}^2} i\beta_n |\hat{u}_1^+(n)|^2 e^{i(\beta_n - \overline{\beta_n})b} + 4\pi^2 \sum_{n \in \mathbb{Z}^2} i\overline{\beta_n} |\hat{u}_1^+(n)|^2 e^{i(\beta_n - \overline{\beta_n})b}.
\end{aligned}$$

Note that in the sum (2.40) all terms that correspond to $Im\beta_n \neq 0$ decay (or grow) exponentially as $|x_3| \rightarrow \infty$. Only waves corresponding to n with $n^2 \leq \omega^2$ may propagate outward. So we may consider the sum only over n such that $n^2 \leq \omega^2$, which means $\beta_n = \overline{\beta_n}$.

Then we can get

$$\int_{\Gamma^+} (\overline{u_1^{i+}} \frac{\partial u_1^{i+}}{\partial x_3} - u_1^{i+} \frac{\partial \overline{u_1^{i+}}}{\partial x_3}) dx = -8\pi^2 i\omega + 8\pi^2 \sum_{n^2 \leq \omega^2} i\beta_n |\hat{u}_1^+(n)|^2. \quad (2.66)$$

This leads us to

$$-8\pi^2 i\omega + 8\pi^2 \sum_{n^2 \leq \omega^2} i\beta_n |\hat{u}_1^+(n)|^2 + \int_{\Gamma} (u_1^{i+} \frac{\partial \overline{u_1^{i+}}}{\partial x_3} - \overline{u_1^{i+}} \frac{\partial u_1^{i+}}{\partial x_3}) dx = 0. \quad (2.67)$$

Applying to (2.39) similarly with $-n$ as a normal unit vector, we obtain

$$8\pi^2 \sum_{n^2 \leq \omega^2} i\beta_n |\hat{u}_1^-(n)|^2 + \int_{\Gamma} (\overline{u_1^-} \frac{\partial u_1^-}{\partial x_3} - u_1^- \frac{\partial \overline{u_1^-}}{\partial x_3}) dx = 0. \quad (2.68)$$

Combining (2.67) and (2.68),

$$\begin{aligned}
& -8\pi^2 i\omega + 8\pi^2 \sum_{n^2 \leq \omega^2} i\beta_n |\hat{u}_1^+(n)|^2 + 8\pi^2 \sum_{n^2 \leq \omega^2} i\beta_n |\hat{u}_1^-(n)|^2 \\
& + \int_{\Gamma} (u_1^{i+} \frac{\partial \overline{u_1^{i+}}}{\partial x_3} - \overline{u_1^{i+}} \frac{\partial u_1^{i+}}{\partial x_3} + \overline{u_1^-} \frac{\partial u_1^-}{\partial x_3} - u_1^- \frac{\partial \overline{u_1^-}}{\partial x_3}) dx = 0.
\end{aligned} \quad (2.69)$$

Applying the same process, we can get the exactly same result for other two components u_2^+, u_3^+ and u_2^-, u_3^- of E without the term $-8\pi^2 i\omega$ obtained from the incident wave, that is,

$$8\pi^2 \sum_{n^2 \leq \omega^2} i\beta_n |\hat{u}_2^+(n)|^2 + 8\pi^2 \sum_{n^2 \leq \omega^2} i\beta_n |\hat{u}_2^-(n)|^2$$

$$+ \int_{\Gamma} (u_2^+ \frac{\partial \overline{u_2^+}}{\partial x_3} - \overline{u_2^+} \frac{\partial u_2^+}{\partial x_3} + \overline{u_2^-} \frac{\partial u_2^-}{\partial x_3} - u_2^- \frac{\partial \overline{u_2^-}}{\partial x_3}) dx = 0 \quad (2.70)$$

and

$$8\pi^2 \sum_{n^2 \leq \omega^2} i\beta_n |\hat{u}_3^+(n)|^2 + 8\pi^2 \sum_{n^2 \leq \omega^2} i\beta_n |\hat{u}_3^-(n)|^2 \\ + \int_{\Gamma} (u_3^+ \frac{\partial \overline{u_3^+}}{\partial x_3} - \overline{u_3^+} \frac{\partial u_3^+}{\partial x_3} + \overline{u_3^-} \frac{\partial u_3^-}{\partial x_3} - u_3^- \frac{\partial \overline{u_3^-}}{\partial x_3}) dx = 0. \quad (2.71)$$

Now adding all results (2.69),(2.70) and (2.71) together,

$$-8\pi^2 i\omega + 8\pi^2 \sum_{j=1}^3 \sum_{n^2 \leq \omega^2} i\beta_n |\hat{u}_j^+(n)|^2 + 8\pi^2 \sum_{j=1}^3 \sum_{n^2 \leq \omega^2} i\beta_n |\hat{u}_j^-(n)|^2 \\ + \int_{\Gamma} (u_1^{i+} \frac{\partial \overline{u_1^{i+}}}{\partial x_3} - \overline{u_1^{i+}} \frac{\partial u_1^{i+}}{\partial x_3} + \overline{u_1^-} \frac{\partial u_1^-}{\partial x_3} - u_1^- \frac{\partial \overline{u_1^-}}{\partial x_3}) dx \\ + \int_{\Gamma} (u_2^+ \frac{\partial \overline{u_2^+}}{\partial x_3} - \overline{u_2^+} \frac{\partial u_2^+}{\partial x_3} + \overline{u_2^-} \frac{\partial u_2^-}{\partial x_3} - u_2^- \frac{\partial \overline{u_2^-}}{\partial x_3}) dx \\ + \int_{\Gamma} (u_3^+ \frac{\partial \overline{u_3^+}}{\partial x_3} - \overline{u_3^+} \frac{\partial u_3^+}{\partial x_3} + \overline{u_3^-} \frac{\partial u_3^-}{\partial x_3} - u_3^- \frac{\partial \overline{u_3^-}}{\partial x_3}) dx = 0. \quad (2.72)$$

But using (2.59), (2.60), (2.63), (2.64) and (2.65),

$$\int_{\Gamma} (u_1^{i+} \frac{\partial \overline{u_1^{i+}}}{\partial x_3} - \overline{u_1^{i+}} \frac{\partial u_1^{i+}}{\partial x_3} + \overline{u_1^-} \frac{\partial u_1^-}{\partial x_3} - u_1^- \frac{\partial \overline{u_1^-}}{\partial x_3}) dx \\ = i\omega \int_{\Gamma} (u_1^{i+} (\frac{1}{i\omega} \frac{\partial \overline{u_3^+}}{\partial x_1} - T_2(u_1^+, u_2^+) + T_2(u_1^i, u_2^i)) - (\frac{1}{i\omega} \frac{\partial u_3^+}{\partial x_1} + T_2(u_1^+, u_2^+) - T_2(u_1^i, u_2^i)) \overline{u_1^{i+}} \\ + \overline{u_1^-} (\frac{1}{i\omega} \frac{\partial u_3^-}{\partial x_1} - T_2(u_1^-, u_2^-)) - u_1^- (\frac{1}{i\omega} \frac{\partial \overline{u_3^-}}{\partial x_1} + T_2(u_1^-, u_2^-))) dx \\ = i\omega \int_{\Gamma} (u_1^{i+} (\frac{1}{i\omega} \frac{\partial \overline{u_3^+}}{\partial x_1} - \overline{v_2^+} - \overline{v_2^i}) - (\frac{1}{i\omega} \frac{\partial u_3^+}{\partial x_1} + v_2^+ + v_2^i) \overline{u_1^{i+}} + \overline{u_1^-} (\frac{1}{i\omega} \frac{\partial u_3^-}{\partial x_1} + v_2^-) \\ - u_1^- (\frac{1}{i\omega} \frac{\partial \overline{u_3^-}}{\partial x_1} - \overline{v_2^-})) dx \\ = i\omega \int_{\Omega} (u_1^- (\frac{1}{i\omega} \frac{\partial \overline{u_3^+}}{\partial x_1} - \overline{v_2^-}) - (\frac{1}{i\omega} \frac{\partial u_3^+}{\partial x_1} + v_2^-) \overline{u_1^-} + \overline{u_1^-} (\frac{1}{i\omega} \frac{\partial u_3^-}{\partial x_1} + v_2^-) \\ - u_1^- (\frac{1}{i\omega} \frac{\partial \overline{u_3^-}}{\partial x_1} - \overline{v_2^-})) dx \\ = \int_{\Omega} (\frac{1}{i\omega} \frac{\partial \overline{u_3^+}}{\partial x_1} \overline{u_1^-} - \frac{\partial u_3^+}{\partial x_1} \overline{u_1^-} + \frac{\partial u_3^-}{\partial x_1} \overline{u_1^-} - \frac{\partial \overline{u_3^-}}{\partial x_1} u_1^-) dx$$

$$= 0,$$

since $u_1^{i+} = u_1^- = 0$ on $\Gamma - \Omega$ and $u_1^{i+} = u_1^-, v_2^{i+} = v_2^-, \frac{\partial u_3^+}{\partial x_1} = \frac{\partial u_3^-}{\partial x_1}$ on the hole Ω . Similarly, using (2.57), (2.58), (2.61), (2.62) and (2.65), we can show that

$$\int_{\Gamma} (u_2^+ \frac{\partial \overline{u_2^+}}{\partial x_3} - \overline{u_2^+} \frac{\partial u_2^+}{\partial x_3} + \overline{u_2^-} \frac{\partial u_2^-}{\partial x_3} - u_2^- \frac{\partial \overline{u_2^-}}{\partial x_3}) dx = 0, \quad (2.73)$$

since $u_2^+ = u_2^- = 0$ on $\Gamma - \Omega$ and $u_2^+ = u_2^-, v_2^+ = v_2^-, \frac{\partial u_3^+}{\partial x_2} = \frac{\partial u_3^-}{\partial x_2}$ on the hole Ω . Furthermore, using the fact that on Ω , $u_3^+ = u_3^-, \frac{\partial u_3^+}{\partial x_3} = \frac{\partial u_3^-}{\partial x_3}$ and on the outside of the hole $\Gamma - \Omega$ $\hat{u}_j^+ = \hat{u}_j^- = 0$ for $j = 1, 2$, and applying (2.42) and (2.43), we can claim that

$$\int_{\Gamma} (u_3^+ \frac{\partial \overline{u_3^+}}{\partial x_3} - \overline{u_3^+} \frac{\partial u_3^+}{\partial x_3} + \overline{u_3^-} \frac{\partial u_3^-}{\partial x_3} - u_3^- \frac{\partial \overline{u_3^-}}{\partial x_3}) dx = 0. \quad (2.74)$$

Thus we can show that boundary integral terms in (2.72) all collapse and it leads us to the following equation

$$-8\pi^2 i\omega + 8\pi^2 \sum_{j=1}^3 \sum_{n^2 \leq \omega^2} i\beta_n |\hat{u}_j^+(n)|^2 + 8\pi^2 \sum_{j=1}^3 \sum_{n^2 \leq \omega^2} i\beta_n |\hat{u}_j^-(n)|^2 = 0. \quad (2.75)$$

This is the desired formula (2.45) for the conservation of energy.

Theorem 9 *Conservation of energy holds for the problem formulation with unregularized operator; the energy radiated away the perfect conductor Γ is the same as that of the incident wave, i.e.,*

$$\sum_{j=1}^3 \sum_{n^2 \leq \omega^2} \frac{\beta_n}{\omega} |u_j^+(n)|^2 + \sum_{j=1}^3 \sum_{n^2 \leq \omega^2} \frac{\beta_n}{\omega} |u_j^-(n)|^2 = 1. \quad (2.76)$$

Although this principle is well-known, our goal with the preceding derivation is to prove that energy conservation follows directly from the boundary problems (2.15) and (2.17).

2.5.2 Energy dissipation for an regularized operator

We introduced the regularization $T_{\delta} = T + \delta J$ in Section 2.3 in order to create a stable solution strategy for the problem. Numerical experiments indicate that the regularization produces energy dissipation. Our goal in this section is to show that the regularized equations can be derived from appropriately formulated boundary conditions, so that there is hope of applying methods from the previous section to establish energy dissipation. We now pose the following boundary problems for the regularized problem, which is expected to generate the energy dissipation.

$$(u_1^+, u_2^+) + (\tilde{u}_1, \tilde{u}_2) = 0 \quad \text{on } \Gamma - \Omega, \quad (2.77)$$

$$(u_1^-, u_2^-) = 0 \quad \text{on } \Gamma - \Omega, \quad (2.78)$$

$$(u_1^+, u_2^+) + (\tilde{u}_1, \tilde{u}_2) = (u_1^-, u_2^-) \quad \text{on } \Omega, \quad (2.79)$$

$$(v_1^+, v_2^+) + (v_1^i, v_2^i) = (v_1^-, v_2^-) \quad \text{on } \Omega, \quad (2.80)$$

$$(T + \delta J)(u_1^+, u_2^+) = (v_1^+, v_2^+) \quad \text{on } \Gamma, \quad (2.81)$$

$$(T + \delta J)(u_1^-, u_2^-) = -(v_1^-, v_2^-) \quad \text{on } \Gamma, \quad (2.82)$$

where every field definition is same as before and the field \tilde{u} is defined by

$$(T + \delta J)\tilde{u} = Tu^i = -v^i,$$

or

$$\tilde{u} = -(T + \delta J)^{-1}v^i.$$

Combining the boundary conditions above with

$$T(u_1^i, u_2^i) = -(v_1^i, v_2^i),$$

we obtain

$$\chi(T + \delta J)\chi(u_1^+, u_2^+) = -\chi(v_1^i, v_2^i) - \chi T\chi(u_1^i, u_2^i), \quad (2.83)$$

where χ is the characteristic function of Ω . With the boundary equations above, we expect to prove that the regularizer term δJ generates the energy dissipation in the sense that the energy radiated away the perfect conducting screen Γ is strictly less than that of the incident wave, i.e.,

$$\sum_{j=1}^3 \sum_{n^2 \leq \omega^2} \frac{\beta_n}{\omega} |u_j^+(n)|^2 + \sum_{j=1}^3 \sum_{n^2 \leq \omega^2} \frac{\beta_n}{\omega} |u_j^-(n)|^2 < 1. \quad (2.84)$$

We leave it for now as an open problem.

2.6 Numerical experiments

We wish to obtain a stable, efficient numerical approximation to the solution (u_1^+, u_2^+) to the problem

$$\chi(T + \delta J)\chi(u_1^+, u_2^+) = -\chi(v_1^i, v_2^i) - \chi T\chi(u_1^i, u_2^i). \quad (2.85)$$

The simplest, but perhaps least accurate approach, is to discretize the domain Γ with a uniform rectangular grid, approximate χ by an indicator function defined on each grid cell, and approximate the operator T using FFTs on the same grid.

We discretize a $2\pi \times 2\pi$ square cell into $N = n^2$ elements, where n is the number of subdivisions in one direction. We approximate fields u_j^+ , u_j^i , and v_j^i for $j = 1, 2$ as constant functions in each element and we define

$$\begin{aligned}\chi &= (\chi_1, \chi_2, \dots, \chi_N)^T, \\ u^+ &= (u_{11}^+, u_{12}^+, \dots, u_{1N}^+, u_{21}^+, u_{22}^+, \dots, u_{2N}^+)^T, \\ u^i &= (u_{11}^i, u_{12}^i, \dots, u_{1N}^i, u_{21}^i, u_{22}^i, \dots, u_{2N}^i)^T, \\ v^i &= (v_{11}^i, v_{12}^i, \dots, v_{1N}^i, v_{21}^i, v_{22}^i, \dots, v_{2N}^i)^T,\end{aligned}$$

where χ_i , u_{ji}^+ , u_{ji}^i and v_{ji}^i are discretized versions of χ , u_j^+ , u_j^i and v_j^i for $j = 1, 2$ and $i = 1 \dots N$, respectively. Consider X be the $2N \times 2N$ diagonal matrix that takes the entries of χ as its diagonal entries

$$X = \begin{pmatrix} \chi & 0 \\ 0 & \chi \end{pmatrix}.$$

Then the equation (2.85) can be written as the following discrete equation

$$X(\tilde{T} + \delta J)Xu^+ = -Xv^i - X\tilde{T}Xu^i, \quad (2.86)$$

where

$$J = \begin{pmatrix} 0 & -I \\ I & 0 \end{pmatrix}$$

I is $N \times N$ identity matrix, and \tilde{T} is the discrete version of the operator T .

The operator T is defined by

$$T \begin{pmatrix} u_1^+ \\ u_2^+ \end{pmatrix} (x) = \sum_{n \in \mathbb{Z}^2} B_n \begin{pmatrix} \hat{u}_1^+(n) \\ \hat{u}_2^+(n) \end{pmatrix} e^{in \cdot x}.$$

Note that the infinite sum above is reduced to a finite sum in the discrete case. The discrete version \tilde{T} of the operator T can be obtained by computing the action of T on vectors forming a basis for the discrete representations of (u_1^+, u_2^+) . We use FFTs to compute the action of T on such vectors (w_1, w_2) and then obtain the Fourier coefficients $\hat{w}_1(n)$ and $\hat{w}_2(n)$ for $|n| \leq \frac{N}{2}$. So $(\hat{T}w)_1(n)$ and $(\hat{T}w)_2(n)$ can be computed as

$$\begin{pmatrix} (\hat{T}w)_1(n) \\ (\hat{T}w)_2(n) \end{pmatrix} = B_n \begin{pmatrix} \hat{w}_1(n) \\ \hat{w}_2(n) \end{pmatrix}.$$

Then $\tilde{T}w$ is computed by using inverse FFTs.

In this section, we carry out some numerical experiments to get profiles of E fields and the transmission spectra for given frequency range, and show the regularization effects that give rise to the energy absorption.

When the incident wave propagates through the medium occupied by a perforated perfect electric conductor, some of the wave is reflected and some is transmitted. The reflected field u_j^+ and transmitted field u_j^- for $j = 1, 2$ can be expressed as

$$u_j^+ = \sum_{n \in \mathbb{Z}^2} \hat{u}_j^+ e^{ik_n \cdot x} \quad (2.87)$$

$$u_j^- = \sum_{n \in \mathbb{Z}^2} \hat{u}_j^- e^{il_n \cdot x}, \quad (2.88)$$

where where $k_n = (n_1, n_2, \beta_n)$, $l_n = (n_1, n_2, -\beta_n)$ and $\beta_n = \sqrt{\omega^2 - n_1^2 - n_2^2}$.

We recall the definitions of the reflected energy r and the transmitted energy t for the coefficients of the reflected and transmitted waves.

$$r = \sum_{j=1}^3 \sum_{n^2 \leq \omega^2} \frac{\beta_n}{\omega} |u_j^+(n)|^2$$

and

$$t = \sum_{j=1}^3 \sum_{n^2 \leq \omega^2} \frac{\beta_n}{\omega} |u_j^-(n)|^2.$$

For our numerical experiments, the incident wave $u^i(x)$ is assumed to have an amplitude of 1 and is polarized along the x_1 -direction, i.e.,

$$u^i(x) = (1, 0, 0)e^{-i\omega x_3}.$$

We carry out the hole arrays of circles with radius of 0.2 and rectangles with side length of 0.4. Figure 2.3 and Figure 2.4 show three components of E field for the hole arrays of circles and rectangles respectively at frequency $\omega = 0.7$ for two values of δ , $\delta = 0$, and $\delta = 0.01$. As we can see in the figures, the parameter δ makes the field profiles smooth. The bottom one is E field at height 0.15 from the plane. We may expect some smoothness of E field at any small distance away from the perfect conductor Γ , due to the decay of evanescent modes, and the expected smoothness of the field is observed in those figures.

Figure 2.5 and Figure 2.6 illustrate the transmission energy spectrum t (black solid line), total energy spectrum $r + t$ (blue dash-dotted line) and relative energy spectrum $t/(r + t)$ (red dashed line) for the hole array of circles computed using different values of δ , $\delta = 0$, 0.001, 0.01, 0.1. Figure 2.7 and Figure 2.8 illustrate the transmission t (black solid line), total energy spectrum $r + t$ (blue dash-dotted line) and relative energy spectrum $t/(r + t)$ (red dashed line) for the hole array of rectangles for δ , $\delta = 0$, 0.001, 0.01, 0.1. In the figures we can see that the peak of transmission is getting weaker as the regularization

parameter δ is greater, and the parameter δ removes mesh-dependent resonances so that the transmission gets smooth. Another characteristic of δ is on the total energy. Without δ , we can check that the conservation law of energy holds. The larger δ is, however, the more energy is absorbed.

In Figure 2.9, we compare the transmission for the hole array of circles and the transmission for the hole array of rectangles. We see that the transmission for the rectangle aperture array is bigger than that for the circle aperture array, which is matched with the result in [9]. Note also the qualitative agreement in computed versus experimental transmission spectra, indicating that the regularized problem gives a reasonable approximation to the physical system.

Figure 2.10 illustrates the effect of the regularization parameter δ for the operator A . Figure 2.10 depicts the eigenvalue distributions of the operator A_δ for $\delta = 0$ (blue o-points) and $\delta = 0.01$ (red x-points). We can see that the eigenvalues are pushed away from the origin with $\delta > 0$, and δ contributes the solvability of the operator equation (2.15) to some extent.

Figure 2.11 depicts energy dissipation dependent on δ for the hole arrays of circles (the blue solid line) and rectangles (the red dashed line). We can see that the greater δ is, the more energy is dissipated, and energy dissipation for the hole array of rectangles is bigger than that for the hole array of circles.

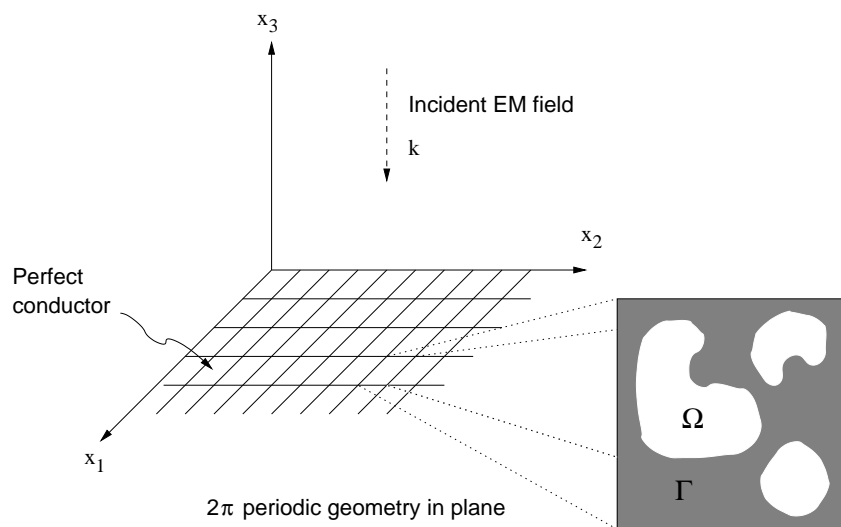

Figure 2.1. Problem geometry for periodic hole arrays.

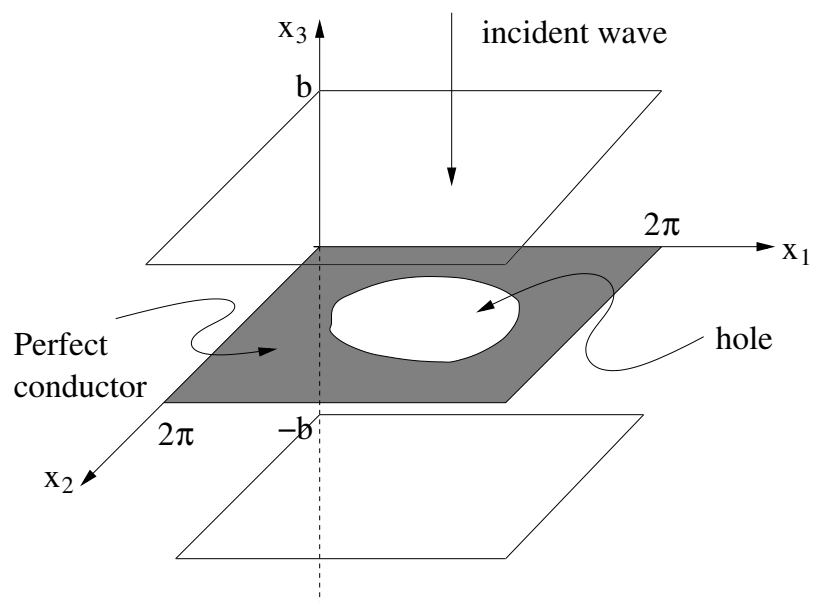

Figure 2.2. Problem geometry for energy conservation.

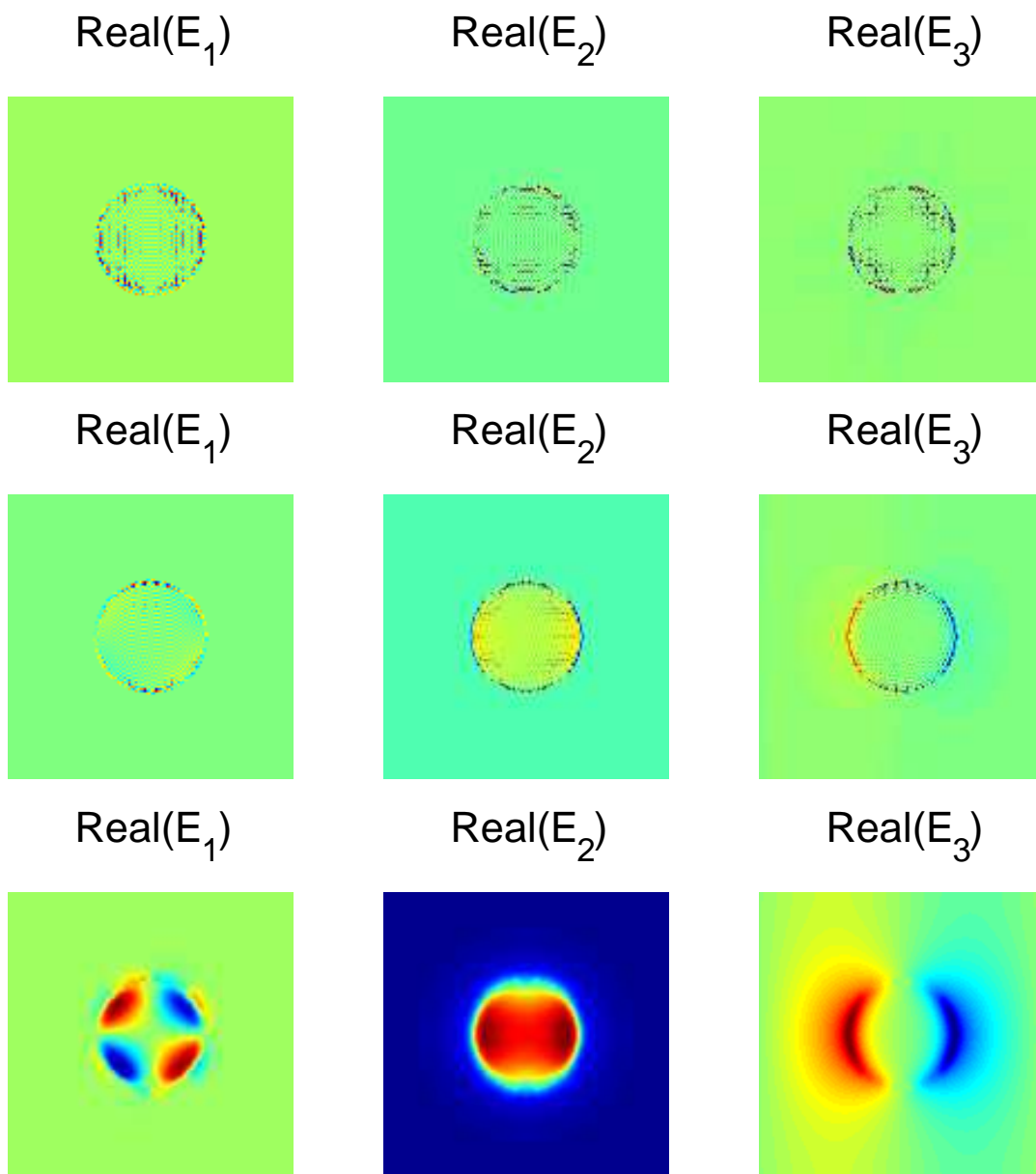

Figure 2.3. Three components of E field for the hole array of circles in the (x_1, x_2) -plane at frequency $\omega = 0.7$. Top is E field with the regularization parameter $\delta = 0$, middle is with $\delta = 0.05$, bottom is with $\delta = 0.05$, height 0.15

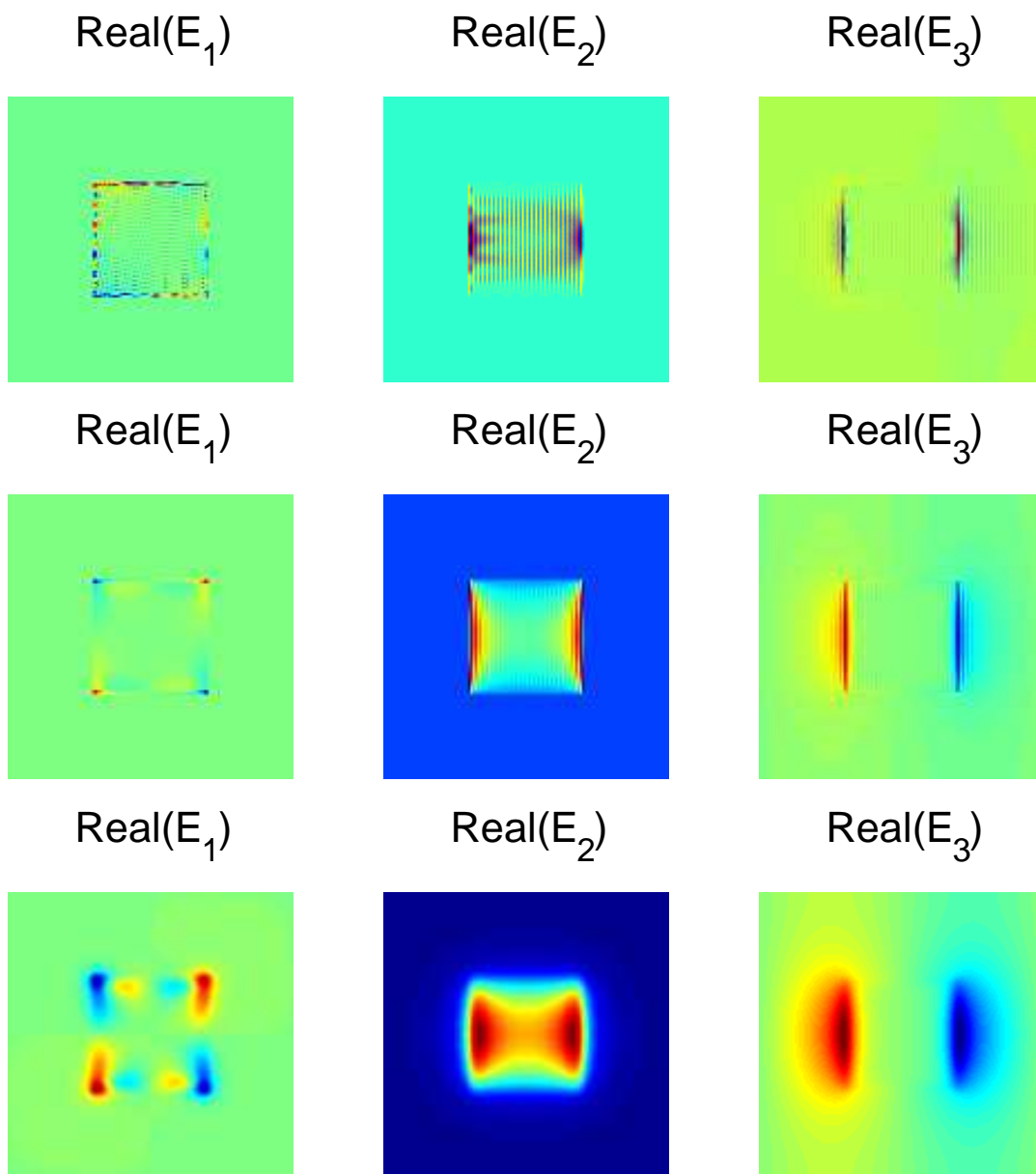

Figure 2.4. Three components of E field for the hole array of rectangles in the (x_1, x_2) -plane at frequency $\omega = 0.7$. Top is E field with the regularization parameter $\delta = 0$, middle is with $\delta = 0.05$, and bottom is with $\delta = 0.05$, height 0.15

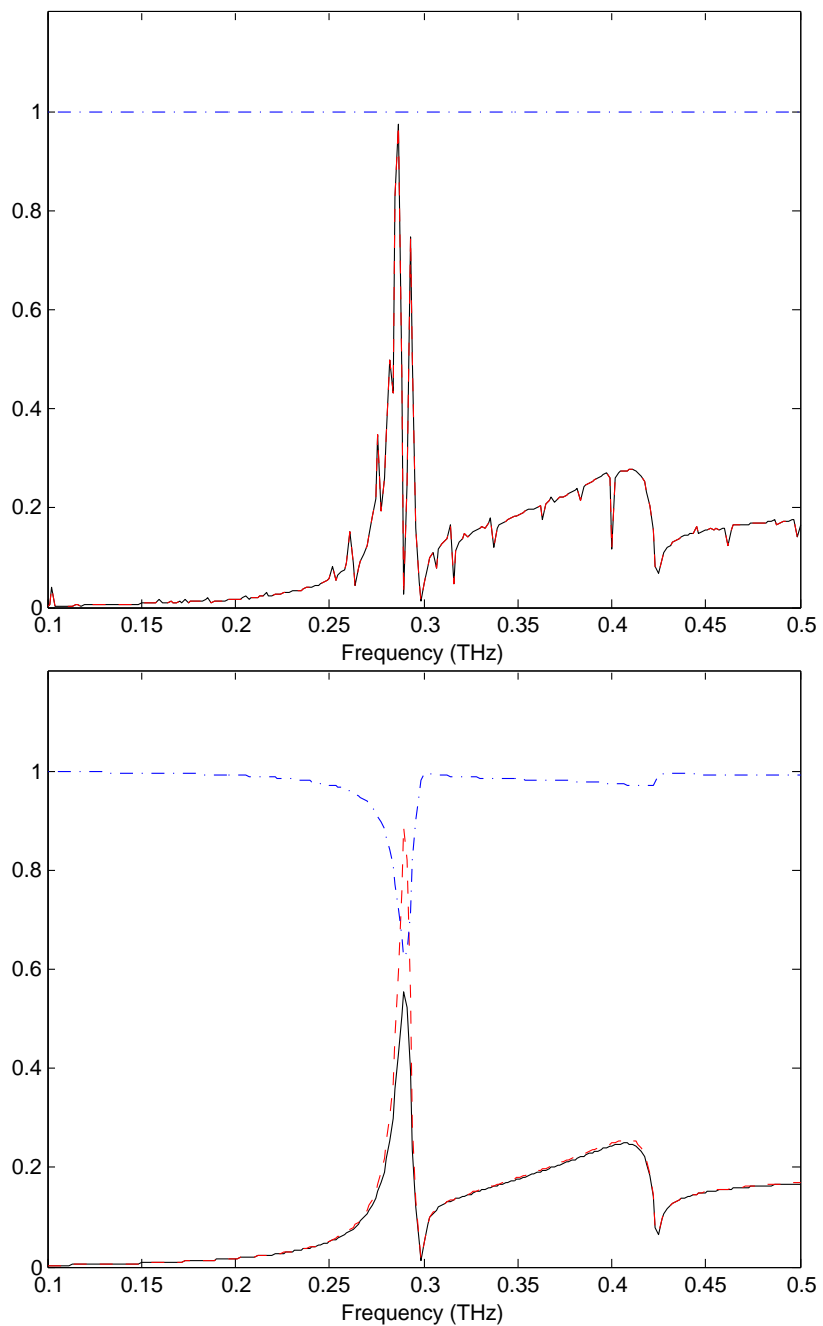

Figure 2.5. Transmission T (black solid line), total energy spectrum $R + T$ (blue dash-dotted line) and relative energy spectrum $T/(R + T)$ (red dashed line) for the hole array of circles computed using different values of δ . Top : $\delta = 0$, bottom : $\delta = 0.001$.

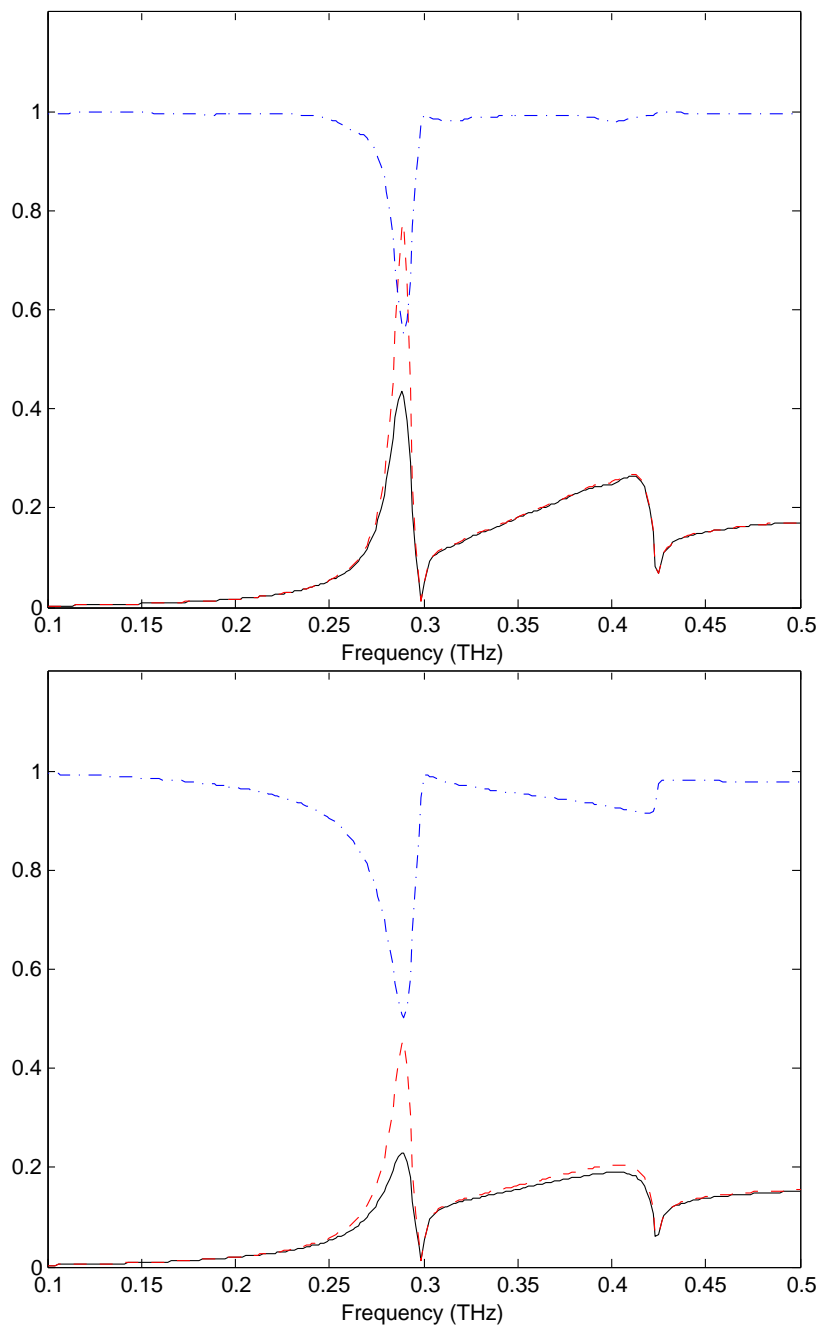

Figure 2.6. Transmission T (black solid line), total energy spectrum $R + T$ (blue dash-dotted line) and relative energy spectrum $T/(R + T)$ (red dashed line) for the hole array of circles computed using different values of δ . Top : $\delta = 0.01$, bottom : $\delta = 0.1$.

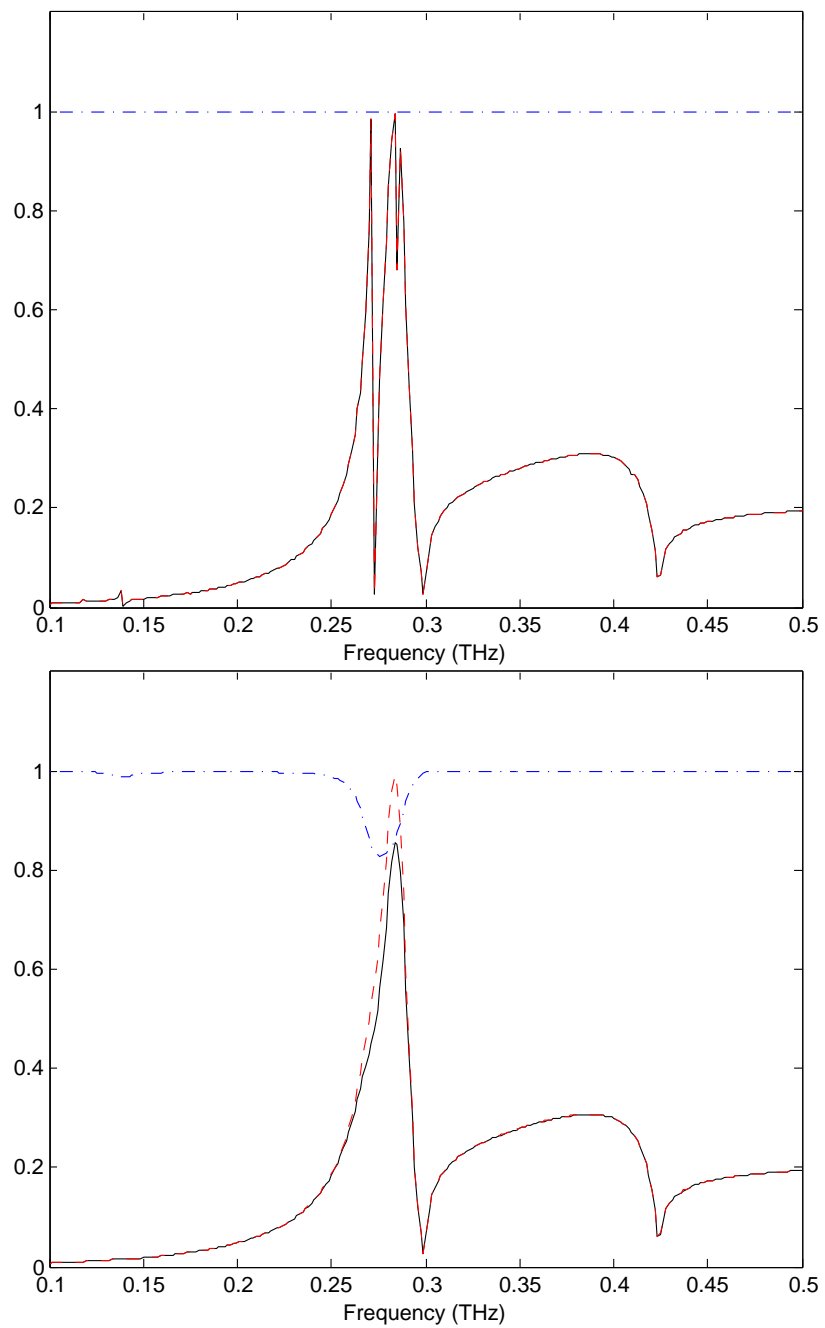

Figure 2.7. Transmission T (black solid line), total energy spectrum $R + T$ (blue dash-dotted line) and relative energy spectrum $T/(R + T)$ (red dashed line) for the hole array of rectangles computed using different values of δ . Top : $\delta = 0$, bottom : $\delta = 0.001$.

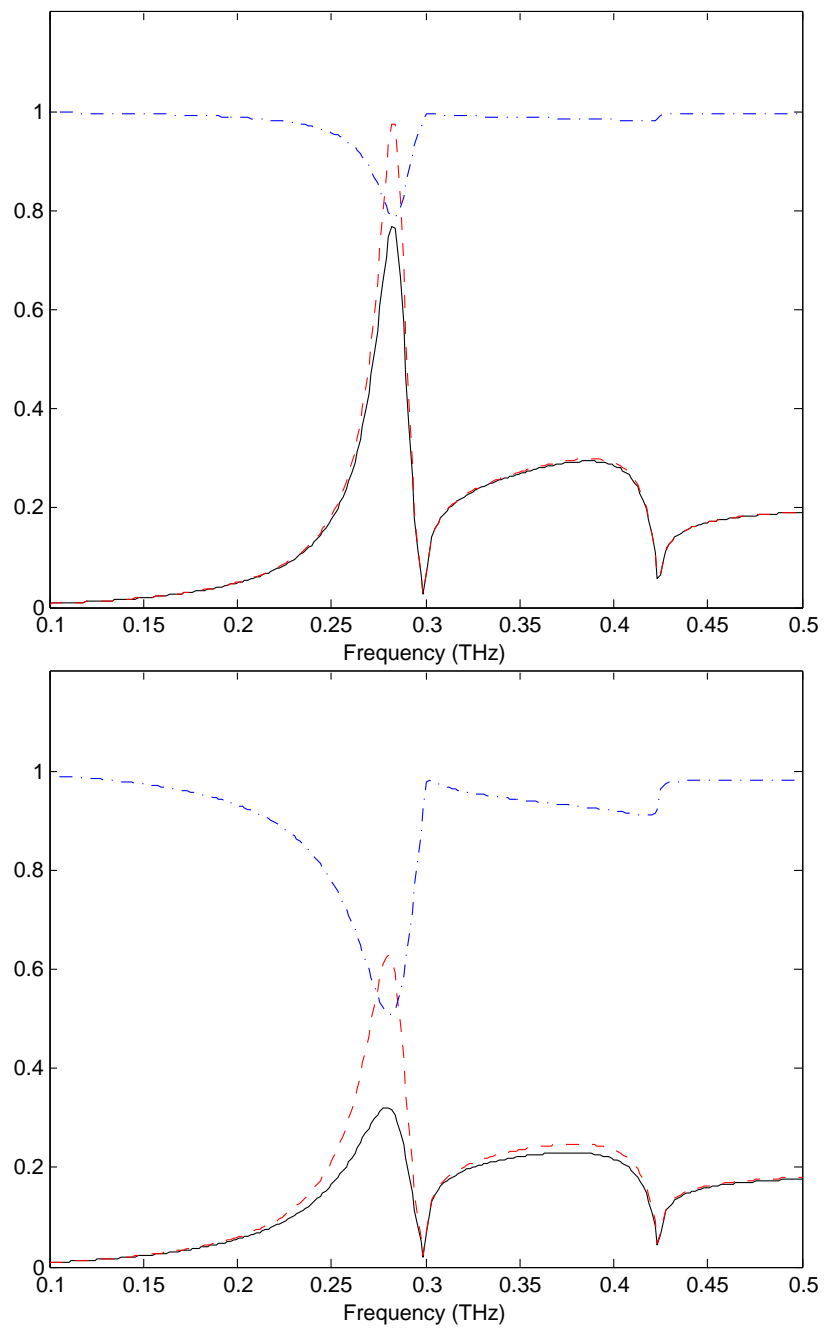

Figure 2.8. Transmission T (black solid line), total energy spectrum $R + T$ (blue dash-dotted line) and relative energy spectrum $T/(R + T)$ (red dashed line) for the hole array of rectangles computed using different values of δ . Top : $\delta = 0.01$, bottom : $\delta = 0.1$.

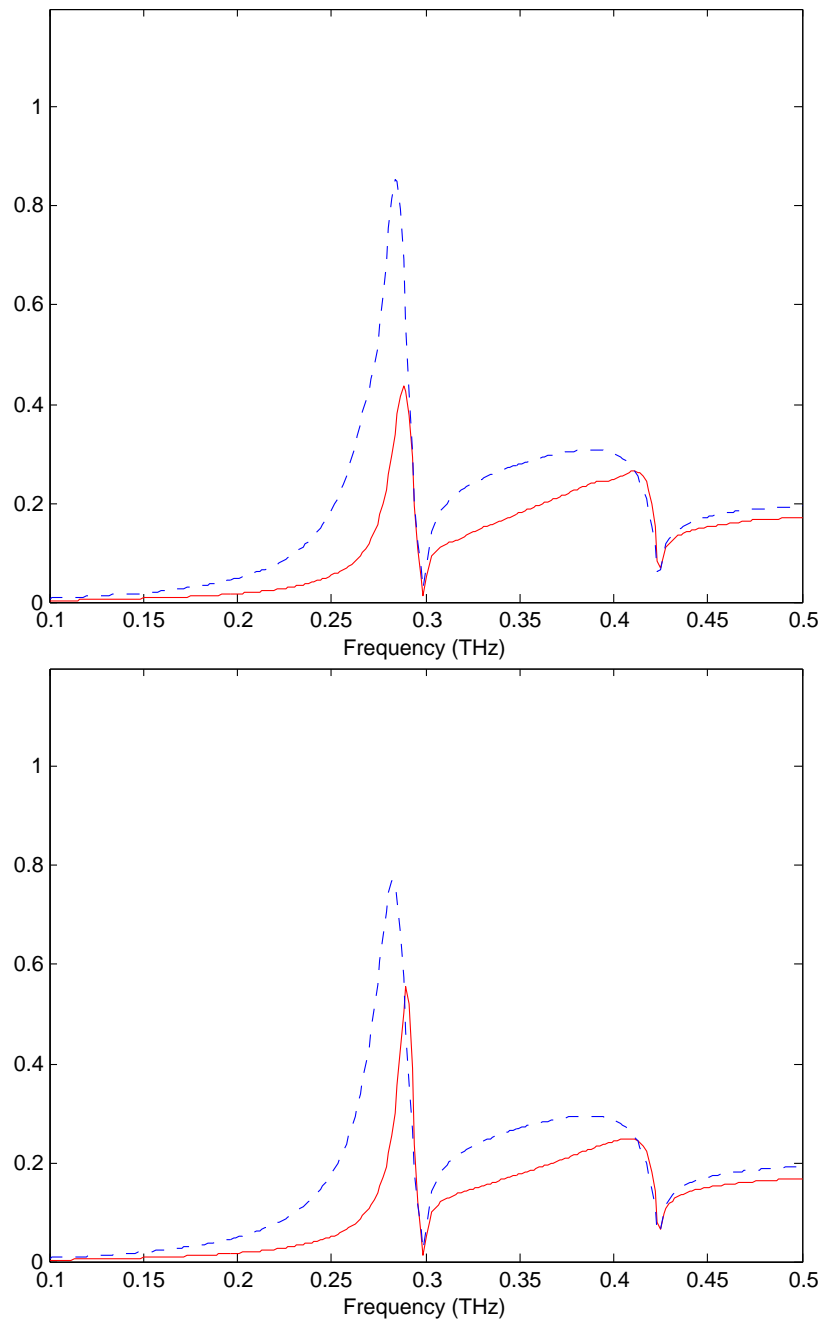

Figure 2.9. Comparison of transmission T for the hole array of circles (red solid line) and transmission T for the hole array of rectangles (blue dashed line).

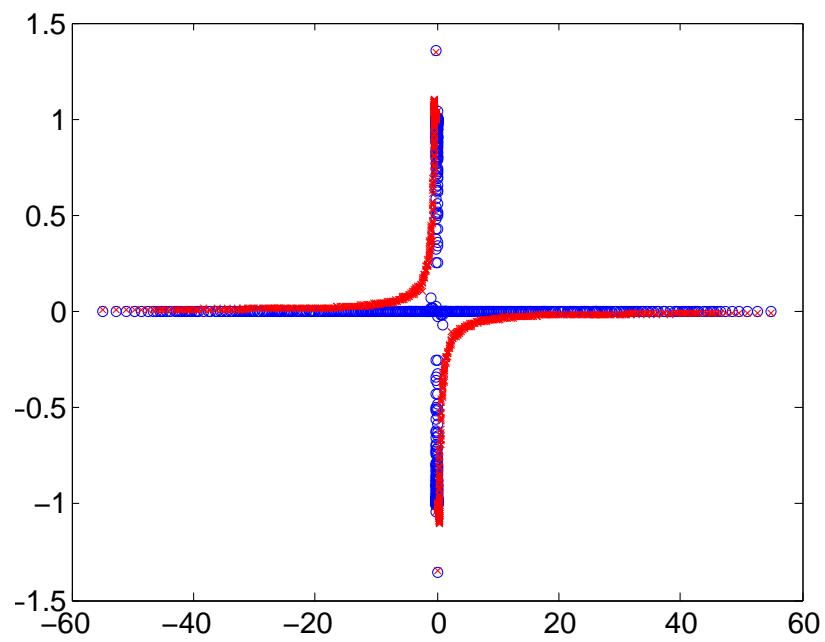

Figure 2.10. Eigenvalue distribution of operator A_δ for the hole arrays of circles with $\delta = 0$ (blue o) and $\delta = 0.01$ (red x).

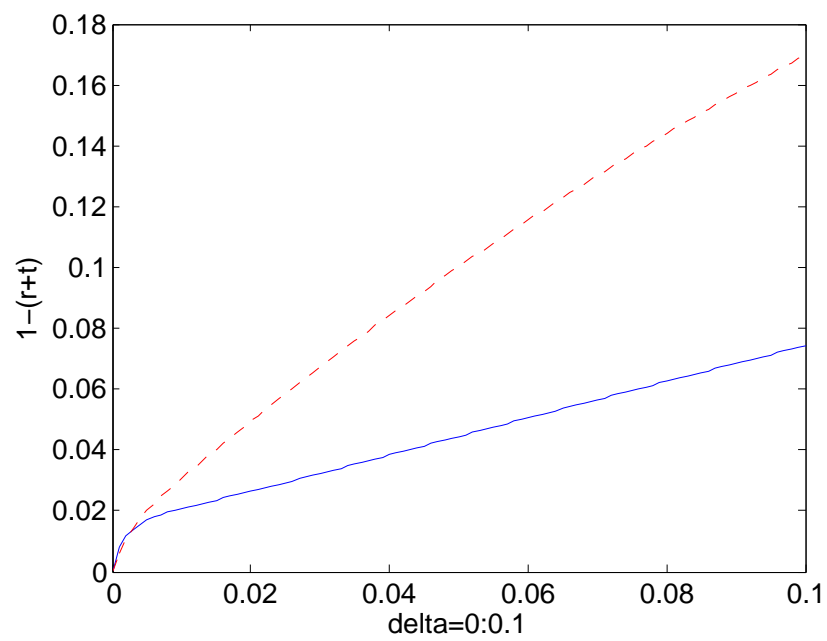

Figure 2.11. Energy dissipation for the hole arrays of circles (blue solid line), and rectangles (red dashed line).

CHAPTER 3

OPTIMIZATION OF TRANSMISSION SPECTRA THROUGH PERIODIC APERTURE ARRAYS

The problem studied in Chapter 2 has several drawbacks. Although the 3D geometry is useful, the assumption of an “infinitely thin perfect conductor” becomes much less physically plausible at optical frequencies. In this chapter, we allow imperfect conductors of finite thickness, and with arbitrary spatial distribution, but restricted to a two-dimensional geometry.

3.1 Model problem

We consider time-harmonic electromagnetic wave propagation through nonmagnetic ($\mu = 1$) heterogeneous media for which the dielectric coefficient is constant in one direction, i.e., $\epsilon(x_1, x_2, x_3) = \epsilon(x_1, x_2)$. We then consider two problems called TE-polarization and TM-polarization respectively. Assuming that the electric field vector $E = (0, 0, u(x_1, x_2))$, Maxwell’s equations reduce to the Helmholtz equation

$$\Delta u + \omega^2 \epsilon(x) u = 0 \quad (\text{TE-polarization}). \quad (3.1)$$

On the other hand, assuming that the magnetic field vector $H = (0, 0, u(x_1, x_2))$ yields

$$\nabla \cdot \left(\frac{1}{\epsilon(x)} \right) \nabla u + \omega^2 u = 0 \quad (\text{TM-polarization}) \quad (3.2)$$

Let D be a bounded domain imbedded in the strip

$$\Omega = \{(x_1, x_2) \in \mathbb{R}^2 : -b < x_2 < b\},$$

where b is some positive constant. We assume that D is 2π -periodic with respect to the integers $\mathbb{Z} = \{0, \pm 1, \pm 2, \dots\}$ in the sense that $(D \cap \{x\}) + (2\pi n, 0) = D \cap \{x + (2\pi n, 0)\}$ for all $n \in \mathbb{Z}$, $x \in \mathbb{R}^2$. Let $\Omega_1 = \{x \in \mathbb{R}^2 : x_2 > b\}$, $\Omega_2 = \{x \in \mathbb{R}^2 : x_2 < -b\}$. Define the

boundaries $\Gamma_1 = \{x_2 = b\}$, $\Gamma_2 = \{x_2 = -b\}$. The problem geometry is described in Figure 3.1.

Suppose that \mathbb{R}^2 is filled with material in such a way that the dielectric coefficient ϵ satisfies

$$\epsilon(x) = \begin{cases} \epsilon_1 & \text{in } (\Omega \setminus D) \cup \overline{\Omega_1} \cup \overline{\Omega_2}, \\ \epsilon_2 & \text{in } D, \end{cases} \quad (3.3)$$

where ϵ_1 and ϵ_2 are (complex) constants. The case $\text{Im}\epsilon_j > 0$ for $j = 1, 2$ accounts for materials which absorb energy. We wish to solve the equations

$$\Delta u + \omega^2 \epsilon(x) u = 0 \text{ in } \mathbb{R}^2 \quad (3.4)$$

$$\nabla \cdot \left(\frac{1}{\epsilon(x)} \right) \nabla u + \omega^2 u = 0 \text{ in } \mathbb{R}^2 \quad (3.5)$$

when an incoming plane wave

$$u_{in} = e^{i\alpha x_1 - i\beta_1 x_2} \quad (3.6)$$

is incident on the structure from Ω_1 . Here ω is the frequency, $(\alpha, -\beta_1)$ is the incidence vector and

$$\alpha^2 + \beta_1^2 = \omega^2 \epsilon_1. \quad (3.7)$$

We are interested in quasiperiodic solutions u , that is, solutions u such that $ue^{-i\alpha x_1}$ is 2π -periodic. Define $u_\alpha = ue^{-i\alpha x_1}$. It is easily seen that solving (3.4) and (3.5) is equivalent to solving the following equations respectively.

$$\Delta_\alpha u_\alpha + \omega^2 \epsilon(x) u_\alpha = 0 \text{ in } \mathbb{R}^2, \quad (3.8)$$

$$\nabla_\alpha \cdot \left(\frac{1}{\epsilon(x)} \right) \nabla_\alpha u_\alpha + \omega^2 u_\alpha = 0 \text{ in } \mathbb{R}^2, \quad (3.9)$$

where $\Delta_\alpha = \nabla_\alpha \cdot \nabla_\alpha$ with $\nabla_\alpha = \nabla + i(\alpha, 0)$.

We expand u_α in a Fourier series :

$$u_\alpha(x_1, x_2) = \sum_{n \in \mathbb{Z}} u_\alpha^n(x_2) e^{inx_1}, \quad (3.10)$$

where

$$u_\alpha^n(x_2) = \frac{1}{2\pi} \int_0^{2\pi} u_\alpha(x_1, x_2) e^{-inx_1} dx_1. \quad (3.11)$$

Define for $j = 1, 2$ the coefficients

$$\beta_j^n(\alpha) = e^{i\gamma/2} |\omega^2 \epsilon_j - (n + \alpha)^2|^{\frac{1}{2}}, \quad n \in \mathbb{Z}, \quad (3.12)$$

where

$$\gamma = \arg(\omega^2 \epsilon_j - (n + \alpha)^2), \quad 0 \leq \gamma < 2\pi. \quad (3.13)$$

Observe that inside Ω_1 and Ω_2 the dielectric coefficients ϵ are constants. The equations (3.8) and (3.9) then become

$$\Delta_\alpha u + \omega^2 \epsilon(x) u_\alpha = 0 \quad \text{in } \Omega_1 \cup \Omega_2, \quad (3.14)$$

where $\Delta_\alpha = \Delta + 2i(\alpha, 0) \cdot \nabla - |\alpha|^2$.

Since the medium in Ω_j is homogeneous, the method of separation of variables implies that u_α can be expressed as a sum of plane waves (See [10] or [13]) :

$$u_\alpha|_{\Omega_j} = \sum_{n \in \mathbb{Z}} a_j^n e^{\pm i\beta_1^n(\alpha)x_2 + inx_1}, \quad j = 1, 2, \quad (3.15)$$

where the a_j^n are complex scalars.

Notice that if $\text{Im}\epsilon_1 = 0$ then

$$\beta_1^n = \begin{cases} (\omega^2 \epsilon_1 - (n + \alpha)^2)^{1/2} & \text{for } \omega^2 \epsilon_1 > (n + \alpha)^2 \\ i((n + \alpha)^2 - \omega^2 \epsilon_1)^{1/2} & \text{for } \omega^2 \epsilon_1 < (n + \alpha)^2. \end{cases} \quad (3.16)$$

Since β_1^n is real for at most finitely many n , there are only a finite number of propagating plane waves in the sum (3.15); the remaining waves are exponentially damped (or unbounded) as $|x_2| \rightarrow \infty$.

From (3.10) and (3.15) we then have the condition that

$$u_\alpha^n(x_2) = \begin{cases} u_\alpha^n(b) e^{i\beta_1^n(\alpha)(x_2-b)}, & n \neq 0, \text{ in } \Omega_1, \\ u_\alpha^0(b) e^{i\beta_1(x_2-b)} + e^{-i\beta_1 x_2} - e^{i\beta_1(x_2-2b)}, & n = 0, \text{ in } \Omega_1, \\ u_\alpha^n(-b) e^{-i\beta_1^n(\alpha)(x_2+b)}, & \text{in } \Omega_2. \end{cases} \quad (3.17)$$

The unit outward normal ν on Ω is

$$\nu = \begin{cases} e_2 & \text{on } \Gamma_1, \\ -e_2 & \text{on } \Gamma_2, \end{cases} \quad (3.18)$$

where e_2 is the unit vector in the direction of the x_2 -axis. From (3.17) we can then calculate the derivative of $u_\alpha^n(x_2)$ with respect to ν on Ω :

$$\left. \frac{\partial u_\alpha^n}{\partial \nu} \right|_{\Gamma_j} = \begin{cases} i\beta_1^n(\alpha) u_\alpha^n(b), & n \neq 0, \text{ on } \Gamma_1, \\ i\beta_1 u_\alpha^0(b) - 2i\beta_1 e^{-\beta_1 b}, & n = 0, \text{ on } \Gamma_1, \\ i\beta_1^n(\alpha) u_\alpha^n(-b) & \text{on } \Gamma_2. \end{cases} \quad (3.19)$$

Thus from (3.10) and (3.19),

$$\left. \frac{\partial u_\alpha}{\partial \nu} \right|_{\Gamma_1} = \sum_{n \in \mathbb{Z}} i\beta_1^n(\alpha) u_\alpha^n(b) e^{inx_1} - 2i\beta_1 e^{-i\beta_1 b}, \quad (3.20)$$

$$\frac{\partial u_\alpha}{\partial \nu} \Big|_{\Gamma_2} = \sum_{n \in \mathbb{Z}} i\beta_1^n(\alpha) u_\alpha^n(-b) e^{inx_1}. \quad (3.21)$$

Since the fields u_α are 2π -periodic in x_1 , we can move the problem from \mathbb{R}^2 to the quotient space (cylinder) $\mathbb{R}^2/(2\pi\mathbb{Z} \times \{0\})$. We shall henceforth identify Ω with the cylinder $\Omega/(2\pi\mathbb{Z} \times \{0\})$, and similarly for the boundaries $\Gamma_j \equiv \Gamma/2\pi\mathbb{Z}$. Thus from now on, all functions defined on Ω and Γ_j are implicitly 2π -periodic in the x_1 variable.

For functions $f \in H^{\frac{1}{2}}(\Gamma_j)$ (the Sobolev space of complex valued functions on the circle), define the operator T_j^α by

$$(T_j^\alpha f)(x_1) = \sum_{n \in \mathbb{Z}} i\beta_j^n(\alpha) f^n e^{inx_1}, \quad (3.22)$$

where

$$f^n = \frac{1}{2\pi} \int_0^{2\pi} f(x_1) e^{-inx_1}, \quad (3.23)$$

and equality is taken in the sense of distributions. Then the operator T_j^α is continuous [33].

From (3.20) and (3.21) we see that

$$T_j^\alpha(u_\alpha|_{\Gamma_j}) = \frac{\partial u_\alpha}{\partial \nu} \Big|_{\Gamma_j}, \quad j = 1, 2, \quad (3.24)$$

that is, T_j^α is a Dirichlet-Neumann map. We will use the abbreviated notation $T_j^\alpha u_\alpha$ to mean $T_j^\alpha(u_\alpha|_{\Gamma_j})$.

3.2 Existence and uniqueness of solutions for TE-polarization

The scattering problem for TE-polarization can be formulated as follows (See [14] for more details) : find $u_\alpha \in H^1(\Omega)$ such that for $g \in L^2(\Omega)$

$$\Delta_\alpha u_\alpha + \omega^2 \epsilon(x) u_\alpha = 0 \text{ in } \Omega, \quad (3.25)$$

$$\left(T_1^\alpha - \frac{\partial}{\partial \nu} \right) u_\alpha = g(x) \text{ on } \Gamma_1, \quad (3.26)$$

$$\left(T_1^\alpha - \frac{\partial}{\partial \nu} \right) u_\alpha = 0 \text{ on } \Gamma_2, \quad (3.27)$$

where

$$\epsilon(x) = \begin{cases} 1 + i\epsilon_i & \text{in } \Omega \setminus D, \\ \epsilon_r + i\epsilon_d & \text{in } D, \end{cases} \quad (3.28)$$

where $\epsilon_r < 0$, $\epsilon_d \geq \epsilon_i > 0$, and ϵ_d is the imaginary part of the metal occupying the medium D . We now introduce the new norm $\|\cdot\|_\alpha$ on $H^1(\Omega)$ defined by for $u \in H^1(\Omega)$,

$$\|u\|_\alpha^2 := \int_\Omega (|\nabla + i(\alpha, 0)u|^2 + |u|^2) dx. \quad (3.29)$$

Since $u(x_1, x_2)$ is periodic in x_1 , u can be written as a Fourier series

$$u(x_1, x_2) = \sum_{n \in \mathbb{Z}} \hat{u}_n(x_2) e^{inx_1} \quad (3.30)$$

Then

$$\begin{aligned} \int_0^{2\pi} |(\partial_{x_1} + i\alpha)u(x_1, x_2)|^2 dx_1 &= C_1 \sum_{n \in \mathbb{Z}} |n + \alpha|^2 \hat{u}_n(x_2) \\ &\geq C_2 \sum_{n \in \mathbb{Z}} n^2 \hat{u}_n(x_2) \\ &= C_3 \int_0^{2\pi} |\partial_{x_1} u(x_1, x_2)|^2 dx_1 \end{aligned}$$

for appropriate constants C_1 , C_2 and C_3 . Therefore

$$\int_{\Omega} |(\nabla + i(\alpha, 0))u(x_1, x_2)|^2 dx \geq C \int_{\Omega} |\nabla u(x_1, x_2)|^2 dx. \quad (3.31)$$

This implies

$$\begin{aligned} \|u\|_{\alpha}^2 &= \int_{\Omega} (|(\nabla + i(\alpha, 0))u|^2 + |u|^2) dx \\ &\geq C \|u\|_{H^1}^2 \end{aligned}$$

for an appropriate constant C . Since also $\|u\|_{\alpha}^2 \leq 2\|u\|_{H^1}^2$, (since $\alpha < 1$), we see that $\|\cdot\|_{\alpha}$ is equivalent to the $H^1(\Omega)$ norm.

Lemma 10 *Let*

$$\epsilon(x) = \begin{cases} 1 + i\epsilon_i & \text{in } \Omega \setminus D, \\ \epsilon_r + i\epsilon_d & \text{in } D, \end{cases} \quad (3.32)$$

where $\epsilon_r < 0$ and $\epsilon_d \geq \epsilon_i > 0$. Assume that $\epsilon_r < -\frac{1}{\omega^2}$. Then the problem (3.25)- (3.27) admits a unique weak solution u_{α} in $H^1(\Omega)$ for all α . Furthermore, there exists a constant C depending on ϵ_i , such that $\|u_{\alpha}\|_{H^1(\Omega)} \leq C(\epsilon_i)$ for all D .

Proof : For convenience we drop the subscript α on solutions. Define for $u, v \in H^1(\Omega)$

$$B(u, v) = \int_{\Omega} \nabla u \cdot \overline{\nabla v} - 2i\alpha \int_{\Omega} (\partial_{x_1} u) \bar{v} + \alpha^2 \int_{\Omega} u \bar{v} - \omega^2 \int_{\Omega} \epsilon u \bar{v}$$

$$- \int_{\Gamma_1} (T_1^\alpha u) \bar{v} - \int_{\Gamma_2} (T_1^\alpha u) \bar{v},$$

and

$$f(v) = - \int_{\Gamma_1} g(x) \bar{v}. \quad (3.33)$$

It is straightforward to show that $B(u, v)$ defines a bounded sesquilinear form over $H^1(\Omega) \times H^1(\Omega)$, and that $f(v)$ is a bounded linear functional on $H^1(\Omega)$. Weak solutions $u \in H^1(\Omega)$ of the problem (3.25)-(3.27) solve the variational problem

$$B(u, v) = f(v) \quad \text{for all } v \in H^1(\Omega). \quad (3.34)$$

The sesquilinear form B uniquely defines a linear operator $A : H^1(\Omega) \rightarrow H^1(\Omega)$ such that $B(u, v) = \langle Au, v \rangle_{H^1(\Omega)}$, and the functional $f(v)$ is uniquely identified with an element $f \in H^1(\Omega)$ such that $f(v) = \langle f, v \rangle_{H^1(\Omega)}$ by reflexivity and an abuse of notation. Problem (3.34) is then equivalently stated

$$Au = f. \quad (3.35)$$

We now show that B is coercive by establishing $|B(u, u)| \geq C > 0$ for all $u \in H^1(\Omega)$ with $\|u\|_\alpha = 1$.

Recall that

$$\begin{aligned} B(u, u) &= \int_{\Omega} \nabla u \cdot \overline{\nabla u} - 2i\alpha \int_{\Omega} (\partial_{x_1} u) \bar{u} + \alpha^2 \int_{\Omega} u \bar{u} - \omega^2 \int_{\Omega} \epsilon u \bar{u} \\ &\quad - \int_{\Gamma_1} (T_1^\alpha u) \bar{u} - \int_{\Gamma_2} (T_1^\alpha u) \bar{u}. \end{aligned}$$

Since $\beta_1^n = \sqrt{\omega^2(1 + i\epsilon_i) - (n + \alpha)^2}$, $\text{Re}\beta_1^n > 0$ and $\text{Im}\beta_1^n > 0$ for all n and α . Let $\beta_1^n = p + iq$ where $p = \text{Re}\beta_1^n$ and $q = \text{Im}\beta_1^n$. Note that

$$\begin{aligned} \int_{\Gamma_j} (T_j^\alpha u) \bar{u} &= \int_{\Gamma_j} \sum_{n \in \Lambda^\pm} i\beta_j^n(\alpha) u_n(\pm b) e^{inx_1} \bar{u} \\ &= \int_{\Gamma_j} \left(\sum_{n \in \Lambda^\pm} i\beta_j^n(\alpha) u_n(\pm b) e^{inx_1} \right) \left(\sum_{m \in \mathbb{Z}} \bar{u}_m(\pm b) e^{-imx_1} \right) \\ &= 2\pi \sum_{n \in \Lambda^\pm} i\beta_j^n(\alpha) |u_n(\pm b)|^2. \end{aligned}$$

Let

$$A := - \int_{\Gamma_1} (T_1^\alpha u) \bar{u} - \int_{\Gamma_2} (T_1^\alpha u) \bar{u}. \quad (3.36)$$

Then

$$A = -2\pi \sum_n i(p + iq) |u_n(b)|^2 - 2\pi \sum_n i(p + iq) |u_n(-b)|^2$$

$$= \operatorname{Re}(A) + i\operatorname{Im}(A),$$

where

$$\operatorname{Re}(A) = 2\pi q \sum_n |u_n(b)|^2 + 2\pi q \sum_n |u_n(-b)|^2 \quad (3.37)$$

and

$$\operatorname{Im}(A) = -2\pi p \sum_n |u_n(b)|^2 - 2\pi p \sum_n |u_n(-b)|^2. \quad (3.38)$$

Note that $\operatorname{Re}(A) > 0$ and $\operatorname{Im}(A) < 0$ since $p > 0$ and $q > 0$.

Hence we can rewrite $B(u, u)$ as follows:

$$\begin{aligned} B(u, u) &= \int_{\Omega} |\nabla u|^2 - 2i\alpha \int_{\Omega} (\partial_{x_1} u) \bar{u} + \alpha^2 \int_{\Omega} |u|^2 - \omega^2 \int_{\Omega} \epsilon |u|^2 + A \\ &= \int_{\Omega} |(\nabla + i(\alpha, 0))u|^2 - \omega^2 \int_{\Omega} \epsilon |u|^2 + A \\ &= \|u\|_{\alpha}^2 - \|u\|_{L^2(\Omega)}^2 - \omega^2 \int_{\Omega} \epsilon |u|^2 + \operatorname{Re}(A) + i\operatorname{Im}(A). \end{aligned}$$

The real and imaginary parts of $B(u, u)$ are

$$\operatorname{Re}(B(u, u)) = \|u\|_{\alpha}^2 - \|u\|_{L^2(\Omega)}^2 - \omega^2 \int_{\Omega \setminus D} |u|^2 - \omega^2 \epsilon_r \int_D |u|^2 + \operatorname{Re}(A), \quad (3.39)$$

$$\operatorname{Im}(B(u, u)) = -\omega^2 \epsilon_i \int_{\Omega \setminus D} |u|^2 - \omega^2 \epsilon_d \int_D |u|^2 + \operatorname{Im}(A). \quad (3.40)$$

Note that since $\epsilon_d \geq \epsilon_i$,

$$|\operatorname{Im}(B(u, u))| \geq \omega^2 \epsilon_i \int_{\Omega} |u|^2 - \operatorname{Im}(A). \quad (3.41)$$

Combining (3.39), (3.40) and (3.41), and assuming $\|u\|_{\alpha} = 1$,

$$\begin{aligned} 2|B(u, u)| &\geq \left| \|u\|_{\alpha}^2 - \|u\|_{L^2(\Omega)}^2 - \omega^2 \int_{\Omega \setminus D} |u|^2 - \omega^2 \epsilon_r \int_D |u|^2 + \operatorname{Re}(A) \right| \\ &\quad + \left| -\omega^2 \epsilon_i \int_{\Omega} |u|^2 + \operatorname{Im}(A) \right| \\ &= \left| 1 - \int_{\Omega} |u|^2 - \omega^2 \int_{\Omega \setminus D} |u|^2 - \omega^2 \epsilon_r \int_D |u|^2 + t_1 \right| \\ &\quad + \omega^2 \epsilon_i \int_{\Omega} |u|^2 - \operatorname{Im}(A) \\ &= \left| 1 - (1 + \omega^2) \int_{\Omega \setminus D} |u|^2 - (1 + \omega^2 \epsilon_r) \int_D |u|^2 + t_1 \right| \end{aligned}$$

$$+\omega^2\epsilon_i \int_{\Omega} |u|^2 - \text{Im}(A).$$

By hypothesis, $1 + \omega^2\epsilon_r < 0$. If $\int_{\Omega \setminus D} |u|^2 < \frac{1}{2(1+\omega^2)}$ then $|B(u, u)| \geq \frac{1}{4}$. If $\int_{\Omega \setminus D} |u|^2 \geq \frac{1}{2(1+\omega^2)}$ then $\int_{\Omega} |u|^2 \geq \frac{1}{2(1+\omega^2)}$, and then $|B(u, u)| \geq \frac{1}{2}\epsilon_i\omega^2 \int_{\Omega} |u|^2 \geq \frac{\epsilon_i\omega^2}{4(1+\omega^2)}$. Hence for all $u \in H^1(\Omega)$ with $\|u\|_{\alpha} = 1$,

$$|B(u, u)| \geq C, \quad (3.42)$$

where

$$C = \min \left\{ \frac{1}{4}, \frac{\epsilon_i\omega^2}{4(1+\omega^2)} \right\}. \quad (3.43)$$

Here the constant C depends only on ϵ_i and ω . This implies the coercivity of $B(u, v)$ on $H^1(\Omega) \times H^1(\Omega)$ and completes the proof.

Remark 11 *The weak solution u_{α} to the problem (3.25)- (3.27) in Lemma 5 is in fact uniformly bounded in $H^2(\Omega)$ since $\Delta u_{\alpha} + \omega^2\epsilon(x)u_{\alpha} = 0$ and ϵu_{α} is uniformly bounded in $L^2(\Omega)$, that is,*

$$\|u_{\alpha}\|_{H^2(\Omega)} \leq C, \quad (3.44)$$

for an appropriate constant C .

3.3 Existence and uniqueness of solutions for TM-polarization

The scattering problem for TM-polarization can be formulated as follows: find $u_{\alpha} \in H^1(\Omega)$ such that for $g \in L^2(\Omega)$

$$\nabla_{\alpha} \cdot \left(\frac{1}{\epsilon(x)} \right) \nabla_{\alpha} u_{\alpha} + \omega^2 u_{\alpha} = 0 \text{ in } \Omega, \quad (3.45)$$

$$\left(T_1^{\alpha} - \frac{\partial}{\partial \nu} \right) u_{\alpha} = g(x) \text{ on } \Gamma_1, \quad (3.46)$$

$$\left(T_1^{\alpha} - \frac{\partial}{\partial \nu} \right) u_{\alpha} = 0 \text{ on } \Gamma_2, \quad (3.47)$$

where

$$\epsilon(x) = \begin{cases} 1 + i\epsilon_i & \text{in } \Omega \setminus D, \\ \epsilon_r + i\epsilon_d & \text{in } D, \end{cases} \quad (3.48)$$

where $\epsilon_r < 0$ and $\epsilon_d \geq \epsilon_i > 0$.

In practice, ϵ depends on ω . We will be considering problems in which ω varies, however for simplicity, we will assume ϵ is constant with respect to ω . The results that follow can be easily modified to account for variable $\epsilon(\omega)$.

Let $\rho(x) = \frac{1}{\epsilon}$. Then the problems (3.45)-(3.47) can be rewritten as

$$\nabla_\alpha \cdot \rho(x) \nabla_\alpha u_\alpha + \omega^2 u_\alpha = 0 \text{ in } \Omega, \quad (3.49)$$

$$\left(T_1^\alpha - \frac{\partial}{\partial \nu} \right) u_\alpha = g(x) \text{ on } \Gamma_1, \quad (3.50)$$

$$\left(T_1^\alpha - \frac{\partial}{\partial \nu} \right) u_\alpha = 0 \text{ on } \Gamma_2. \quad (3.51)$$

Lemma 12 *Let*

$$\rho(x) = \begin{cases} 1 + i\rho_i & \text{in } \Omega \setminus D, \\ \rho_r + i\rho_d & \text{in } D, \end{cases} \quad (3.52)$$

where $\rho_r < 0$, $\rho_i < 0$, and $\rho_d < 0$. Then the problem (3.49)-(3.51) admits a unique weak solution u_α in $H^1(\Omega)$ for all α . Furthermore, there exists a constant C depending on ρ , such that $\|u_\alpha\|_{H^1(\Omega)} \leq C(\rho)$ for all D .

Proof : For convenience we drop the subscript α on solutions. Define for $u, v \in H^1(\Omega)$

$$\begin{aligned} B(u, v) &= \int_\Omega \rho((\nabla + i\alpha)u) \overline{((\nabla + i\alpha)v)} - \omega^2 \int_\Omega u \bar{v} \\ &\quad - \int_{\Gamma_1} \rho(T_1^\alpha u) \bar{v} - \int_{\Gamma_2} \rho(T_2^\alpha u) \bar{v}, \end{aligned}$$

and

$$f(v) = - \int_{\Gamma_b} g(x) \bar{v}. \quad (3.53)$$

It is straightforward to show that $B(u, v)$ defines a bounded sesquilinear form over $H^1(\Omega) \times H^1(\Omega)$, and that $f(v)$ is a bounded linear functional on $H^1(\Omega)$. Weak solutions $u \in H^1(\Omega)$ of the problem (3.49)-(3.51) solve the variational problem

$$B(u, v) = f(v) \quad \text{for all } v \in H^1(\Omega). \quad (3.54)$$

We now show that B is coercive by establishing $|B(u, u)| \geq C\|u\|_\alpha^2$ for all $u \in H^1(\Omega)$.

$$\begin{aligned} B(u, u) &= \int_\Omega \rho |(\nabla + i\alpha)u|^2 - \omega^2 \int_\Omega |u|^2 \\ &\quad - \int_{\Gamma_1} \rho(T_1^\alpha u) \bar{u} - \int_{\Gamma_2} \rho(T_2^\alpha u) \bar{u}, \end{aligned}$$

Since $\beta_1^n = \sqrt{\frac{\omega^2}{\rho} - (n + \alpha)^2} = \sqrt{\omega^2 \epsilon - (n + \alpha)^2}$, $Re\beta_1^n > 0$ and $Im\beta_1^n > 0$ for all n and α . Let $\beta_1^n = p + iq$ where $p = Re\beta_1^n$ and $q = Im\beta_1^n$. Let

$$A := - \int_{\Gamma_1} \rho(T_1^\alpha u) \bar{u} - \int_{\Gamma_2} \rho(T_2^\alpha u) \bar{u}. \quad (3.55)$$

Then

$$A = - \int_{\Gamma_1} (1 + i\rho_i)(T_1^\alpha u) \bar{u} - \int_{\Gamma_2} (1 + i\rho_i)(T_1^\alpha u) \bar{u}$$

$$\begin{aligned}
&= -2\pi \sum_n i(p+iq)|u_n(b)|^2 - 2\pi \sum_n i(p+iq)|u_n(-b)|^2 \\
&\quad + 2\pi\rho_i \sum_n (p+iq)|u_n(b)|^2 + 2\pi\rho_i \sum_n i(p+iq)|u_n(-b)|^2 \\
&= \operatorname{Re}(A) + i\operatorname{Im}(A),
\end{aligned}$$

where

$$\begin{aligned}
\operatorname{Re}(A) &= 2\pi q \sum_n |u_n(b)|^2 + 2\pi q \sum_n |u_n(-b)|^2 \\
&\quad + 2\pi\rho_i p \sum_n |u_n(b)|^2 + 2\pi\rho_i p \sum_n |u_n(-b)|^2
\end{aligned}$$

and

$$\begin{aligned}
\operatorname{Im}(A) &= -2\pi p \sum_n |u_n(b)|^2 - 2\pi p \sum_n |u_n(-b)|^2 \\
&\quad + 2\pi\rho_i q \sum_n |u_n(b)|^2 + 2\pi\rho_i q \sum_n |u_n(-b)|^2.
\end{aligned}$$

Note that $\operatorname{Im}(A) < 0$ since $\rho_i < 0$.

The real part and imaginary part of $B(u, u)$ are given

$$\operatorname{Re}(B(u, u)) = \int_{\Omega \setminus D} |(\nabla + i\alpha)u|^2 + \int_D \rho_r |(\nabla + i\alpha)u|^2 - \omega^2 \int_{\Omega} |u|^2 + \operatorname{Re}(A) \quad (3.56)$$

and

$$\operatorname{Im}(B(u, u)) = \int_{\Omega \setminus D} \rho_i |(\nabla + i\alpha)u|^2 + \int_D \rho_d |(\nabla + i\alpha)u|^2 + \operatorname{Im}(A). \quad (3.57)$$

Note that

$$\begin{aligned}
|\operatorname{Im}(B(u, u))| &= \int_{\Omega \setminus D} (-\rho_i) |(\nabla + i\alpha)u|^2 + \int_D (-\rho_d) |(\nabla + i\alpha)u|^2 - \operatorname{Im}(A) \\
&\geq C \int_{\Omega} |(\nabla + i\alpha)u|^2 - \operatorname{Im}(A),
\end{aligned}$$

where $C = \min\{-\rho_i, -\rho_d\}$. Since $|B(u, u)| \geq |\operatorname{Im}(B(u, u))|$,

$$|B(u, u)| \geq C(\|(\nabla + i\alpha)u\|_{L^2(\Omega)}^2 + |u_0(-b)|^2) \quad (3.58)$$

for an appropriate constant C . Notice that

$$\left| \int_{\Omega} u(x_1, x_2) dx \right|^2 \leq C(|u_0(-b)|^2 + \|(\nabla + i\alpha)u\|_{L^2(\Omega)}^2) \quad (3.59)$$

and

$$\|u\|_{L^2(\Omega)}^2 \leq C(\|(\nabla + i\alpha)u\|_{L^2(\Omega)}^2 + \left| \int_{\Omega} u(x_1, x_2) dx \right|^2). \quad (3.60)$$

Then

$$|B(u, u)| \geq C(\|(\nabla + i\alpha)u\|_{L^2(\Omega)}^2 + |u_0(-b)|^2)$$

$$\begin{aligned}
&\geq \frac{C}{2}(\|(\nabla + i\alpha)u\|_{L^2(\Omega)}^2 + |u_0(-b)|^2) + \frac{C}{2}(\|(\nabla + i\alpha)u\|_{L^2(\Omega)}^2 + |u_0(-b)|^2) \\
&\geq \frac{C}{2}\|(\nabla + i\alpha)u\|_{L^2(\Omega)}^2 + \frac{C}{2}\left|\int_{\Omega} u(x_1, x_2)dx\right|^2 \\
&\geq \frac{C}{4}(\|(\nabla + i\alpha)u\|_{L^2(\Omega)}^2 + \left|\int_{\Omega} u(x_1, x_2)dx\right|^2) \\
&\quad + \frac{C}{4}(\|(\nabla + i\alpha)u\|_{L^2(\Omega)}^2 + \left|\int_{\Omega} u(x_1, x_2)dx\right|^2) \\
&\geq \frac{C}{4}\|(\nabla + i\alpha)u\|_{L^2(\Omega)}^2 + \frac{C}{4}\|u\|_{L^2(\Omega)}^2 \\
&\geq C\|u\|_{\alpha}^2 \\
&\geq C\|u\|_{H^1(\Omega)}^2,
\end{aligned}$$

for an appropriate constant C . This implies the coercivity of $B(u, v)$ on $H^1(\Omega) \times H^1(\Omega)$ and completes the proof.

We need more regularity on the solution u to guarantee the solvability of the minimization problem that will be discussed in the next section.

Lemma 13 *Let u be a solution to*

$$\nabla \cdot \rho(x)\nabla u + \omega^2 u = 0 \text{ in } \Omega, \quad (3.61)$$

$$\left(T_1 - \frac{\partial}{\partial \nu}\right)u = 2i\beta_1 e^{-i\beta_1 b} \text{ on } \Gamma_1, \quad (3.62)$$

$$\left(T_1 - \frac{\partial}{\partial \nu}\right)u = 0 \text{ on } \Gamma_2. \quad (3.63)$$

Assume $\rho \in W^{1,\infty}(\bar{\Omega})$, $\|\rho\|_{1,\infty} \leq \alpha$, and $-\infty < \rho_i \leq b < 0$, where ρ_i is the imaginary part of ρ . Assume also that $\omega^2 \leq \omega_1^2$. Then $u \in H^2(\Omega)$ and

$$\|u\|_{H^2(\Omega)} \leq C,$$

where the constant C depends only on ρ , and ω_1 .

Proof : Since u is the solution to (3.61)-(3.63), it results from Lemma 12 that

$$\|u\|_{H^1(\Omega)} \leq C,$$

for an appropriate constant. Since the solution u satisfies (3.61),

$$\rho\Delta u + \nabla\rho \cdot \nabla u + \omega^2 u = 0,$$

or

$$\Delta u = \frac{1}{\rho}(-\nabla \rho \cdot \nabla u - \omega^2 u).$$

Since

$$\frac{1}{\|\rho\|_\infty} \leq C_1$$

and

$$\|\nabla \rho\|_\infty \leq \|\rho\|_{C^1} \leq C_2$$

for appropriate constants C_1 and C_2 ,

$$\begin{aligned} \|\Delta u\|_{L^2} &\leq C(\|\nabla \rho\|_\infty \|\nabla u\|_{L^2} + \omega^2 \|u\|_{L^2}) \\ &\leq C\|u\|_{H^1} \\ &\leq C. \end{aligned}$$

Hence

$$\|u\|_{H^2} \leq C,$$

for an appropriate constant C .

3.3.1 Optimal design

3.3.1.1 Minimization problem

Consider the TM polarization problem

$$\nabla \cdot \rho(x) \nabla u + \omega^2 u = 0 \text{ in } \Omega, \quad (3.64)$$

$$\left(T_1 - \frac{\partial}{\partial \nu}\right) u = 2i\beta_1 e^{-i\beta_1 b} \text{ on } \Gamma_1, \quad (3.65)$$

$$\left(T_2 - \frac{\partial}{\partial \nu}\right) u = 0 \text{ on } \Gamma_2, \quad (3.66)$$

where $\rho(x) = \frac{1}{\epsilon(x)}$. Let \mathcal{A} be an admissible set given by

$$\begin{aligned} \mathcal{A} &= \{\rho \in W^{1,\infty}(\bar{\Omega}) : -\infty < a_1 \leq \operatorname{Re}(\rho) \leq a_2 < +\infty, \\ &\quad -\infty < b_1 \leq \operatorname{Im}(\rho) \leq b_2 < 0 \text{ a.e. and } \|\rho\|_{1,\infty} \leq C\}, \end{aligned} \quad (3.67)$$

where C is a constant. The transmission energy depends implicitly on the unknown structure and henceforth on the dielectric constant ρ . Let $F(\rho, \omega)$ be the transmission energy defined by

$$F(\rho, \omega) = \frac{1}{2\pi} \sum_{n^2 \leq \omega^2} \frac{\beta_n}{\beta_1} \left| \int_{\Gamma_2} u e^{-inx_1} \right|^2, \quad (3.68)$$

where u solves (3.64),(3.65) and (3.66). Now we pose the following minimization problem

$$\min_{\rho \in \mathcal{A}} J[\rho] = \int_{\omega_0}^{\omega_1} \|F(\rho, \omega) - g(\omega)\|_2^2 d\omega, \quad (3.69)$$

where $g(\omega)$ is a prescribed energy.

Theorem 14 *The minimization problem (3.69) has at least one solution $\rho \in \mathcal{A}$.*

Proof : Choose a minimizing sequence $\{\rho_n\} \subset \mathcal{A}$. Since $\{\rho_n\}$ is bounded in $W^{1,\infty}(\Omega)$, and the imbedding $W^{1,\infty} \rightarrow L^\infty$ is compact, $\{\rho\}$ has a convergent subsequence $\{\rho_n\}$ (still denoted by $\{\rho_n\}$) such that $\rho_n \rightarrow \rho$ in $L^\infty(\Omega)$ for some $\rho \in L^\infty(\Omega)$. We now claim $\rho \in \mathcal{A}$. For all x and y in Ω ,

$$\begin{aligned} |\rho(x) - \rho(y)| &= |\rho(x) - \rho_n(x) + \rho_n(x) - \rho(y) + \rho_n(y) - \rho_n(y)| \\ &\leq |\rho(x) - \rho_n(x)| + |\rho(y) - \rho_n(y)| + |\rho_n(x) - \rho_n(y)| \end{aligned}$$

holds for all n , x , and y .

For x and y fixed,

$$|\rho(x) - \rho(y)| \leq |\rho_n(x) - \rho_n(y)| + \varepsilon \leq |x - y| + \varepsilon$$

for $\varepsilon > 0$. Choose n large enough. Then we obtain

$$|\rho(x) - \rho(y)| \leq |x - y|,$$

which implies that ρ is Lipschitz continuous with constant 1. By following the argument in [16], we have $\|\rho\|_{1,\infty} \leq 1$. Thus it follows that $\rho \in \mathcal{A}$.

Denote by $u_n(\omega)$ the family of solutions to the variational problems corresponding to ρ_n . For each $\omega \in [\omega_0, \omega_1]$, by Lemma 13, the sequence $\{u_n(\omega)\}$ has a weakly convergent subsequence $\{u_n\}$ (still denoted by $\{u_n\}$) such that $u_n \rightharpoonup u$ weakly in $H^2(\Omega)$ for some $u \in H^2(\Omega)$. By compact imbedding theorem on Sobolev space, $u_n \rightarrow u$ strongly in $H^1(\Omega)$, that is, $\|\nabla u_n - \nabla u\|_{L^2(\Omega)} \rightarrow 0$ and $\|u_n - u\|_{L^2(\Omega)} \rightarrow 0$. Now we consider two bilinear forms $B_{\rho_n}(u_n, v)$ and $B_\rho(u, v)$ given by

$$\begin{aligned} B_{\rho_n}(u_n, v) &= \int_{\Omega} \rho_n \nabla u_n \cdot \overline{\nabla v} - \omega^2 \int_{\Omega} u_n \bar{v} - \int_{\Gamma_j} (\nabla u_n) \bar{v}, \\ B_\rho(u, v) &= \int_{\Omega} \rho \nabla u \cdot \overline{\nabla v} - \omega^2 \int_{\Omega} u \bar{v} - \int_{\Gamma_j} (\nabla u) \bar{v}, \end{aligned}$$

for $j = 1, 2$. Then we now claim that $B_{\rho_n}(u_n, v) \rightarrow B_\rho(u, v)$.

$$\left| \int_{\Omega} \rho_n \nabla u_n \overline{\nabla v} - \rho \nabla u \overline{\nabla v} \right|$$

$$\begin{aligned}
&= \left| \int_{\Omega} \rho_n \nabla u_n \overline{\nabla v} - \rho_n \nabla u \overline{\nabla v} + \rho_n \nabla u \overline{\nabla v} - \rho \nabla u \overline{\nabla v} \right| \\
&\leq \left| \int_{\Omega} \rho_n (\nabla u_n \overline{\nabla v} - \nabla u \overline{\nabla v}) \right| + \left| \int_{\Omega} (\rho_n - \rho) \nabla u \overline{\nabla v} \right| \\
&\leq \|\rho_n\|_{L^\infty} \|\nabla u_n - \nabla u\|_{L^2}^2 \|\overline{\nabla v}\|_{L^2}^2 + \left| \int_{\Omega} (\rho_n - \rho) \nabla u \overline{\nabla v} \right|.
\end{aligned}$$

Since $\|\rho_n\|_{L^\infty}$ and $\|\overline{\nabla v}\|_{L^2}^2$ are bounded, $\|\nabla u_n - \nabla u\|_{L^2}^2 \rightarrow 0$, $\nabla u \overline{\nabla v} \in L^1$, and $\rho_n \rightarrow \rho$ in $L^\infty(\Omega)$, $\left| \int_{\Omega} \rho_n \nabla u_n \overline{\nabla v} - \rho \nabla u \overline{\nabla v} \right| \rightarrow 0$. Since $u_n \overline{v} \rightarrow u \overline{v}$ strongly in L^1 , $\left\| \int_{\Omega} (u_n - u) \overline{v} \right\| \rightarrow 0$. Also since $T_j : H^{\frac{1}{2}}(\Gamma_j) \rightarrow H^{-\frac{1}{2}}(\Gamma_j)$ is continuous, $\left\| \int_{\Gamma_j} (\nabla u_n - \nabla u) \overline{v} \right\| \rightarrow 0$ for $j = 1, 2$. Putting this all together, we get $B_{\rho_n}(u_n, v) \rightarrow B_\rho(u, v)$. Hence $u(\omega)$ is the unique solution to the variational problem, for each ω .

Since $u_n \rightarrow u$ in $H^1(\Omega)$, the traces are also convergent, $u_n|_{\Gamma_2} \rightarrow u|_{\Gamma_2}$, in $H^{\frac{1}{2}}(\Gamma_2)$. It follows immediately by the definition (3.68) that $F : \mathcal{A} \rightarrow H^{\frac{1}{2}}(\Gamma)$ is L^∞ continuous. Thus the minimization problem has at least one solution $\rho \in \mathcal{A}$.

3.4 Numerical experiments

In this section, we present some numerical experiments regarding the model introduced in Chapter 3.

We now briefly describe the numerical method used to approximate the solution to the scattering problem (3.45)-(3.47). The problem was solved with a finite element method (See [4], [26] for reference). We discretize the domain Ω with a uniform rectangular 128×65 grid and the fields were approximated with piecewise bilinear basis elements. The material coefficients ρ were parametrized by piecewise constant functions, supported on the cells of the grid. The boundary operators T_j^α were approximated by truncating the Fourier series expansion. The linear system resulting from the finite element method was solved by a direct sparse solver (MATLAB).

Surface plasmon polaritons occur at the interface between dielectrics and good conductors due to the excitation of free electrons in the conductor by an incoming photon. Figure 3.2 illustrates the magnetic field profiles and indicates the appearance of such an excitation at interface.

Figure 3.3 and Figure 3.4 depict the transmission energy spectrum for the structure (Figure 3.5) with imaginary part $\rho_i = 0$, $\rho_i = 0.00001$, $\rho_i = 0.0001$, $\rho_i = 0.002$, where the frequency ω ranges from 0.85 to 0.95. If we consider the periodic slits structure and assume the magnetic field H is parallel to the direction of the slit (TM-polarization), then we can see that the transmission energy spectrum of the three dimensional geometry in Chapter

2 agrees quantitatively with the result in this chapter. In fact, the model of volumetric media exhibits similar characteristics to the model of an infinitely thin perfect conductor. We see that the transmission energy has similar peaks at some frequency as our first model through these figures. Also, as the imaginary part ρ_i is increased, the peaks are reduced.

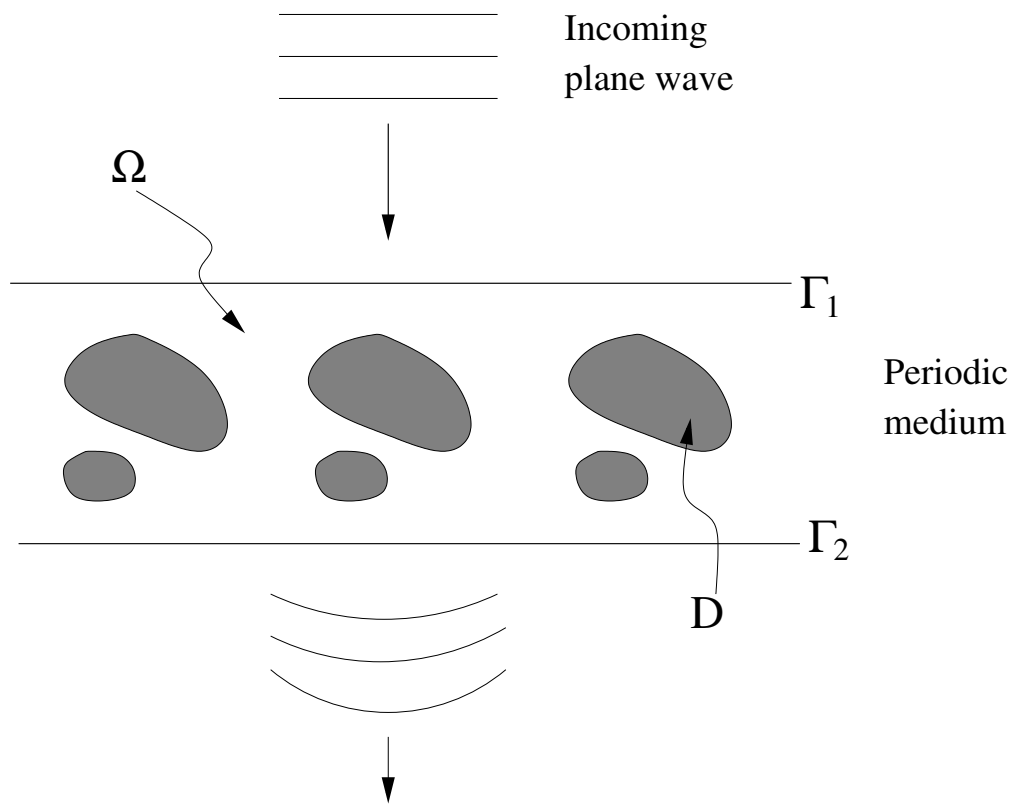

Figure 3.1. Problem geometry for periodic plasmonic structure.

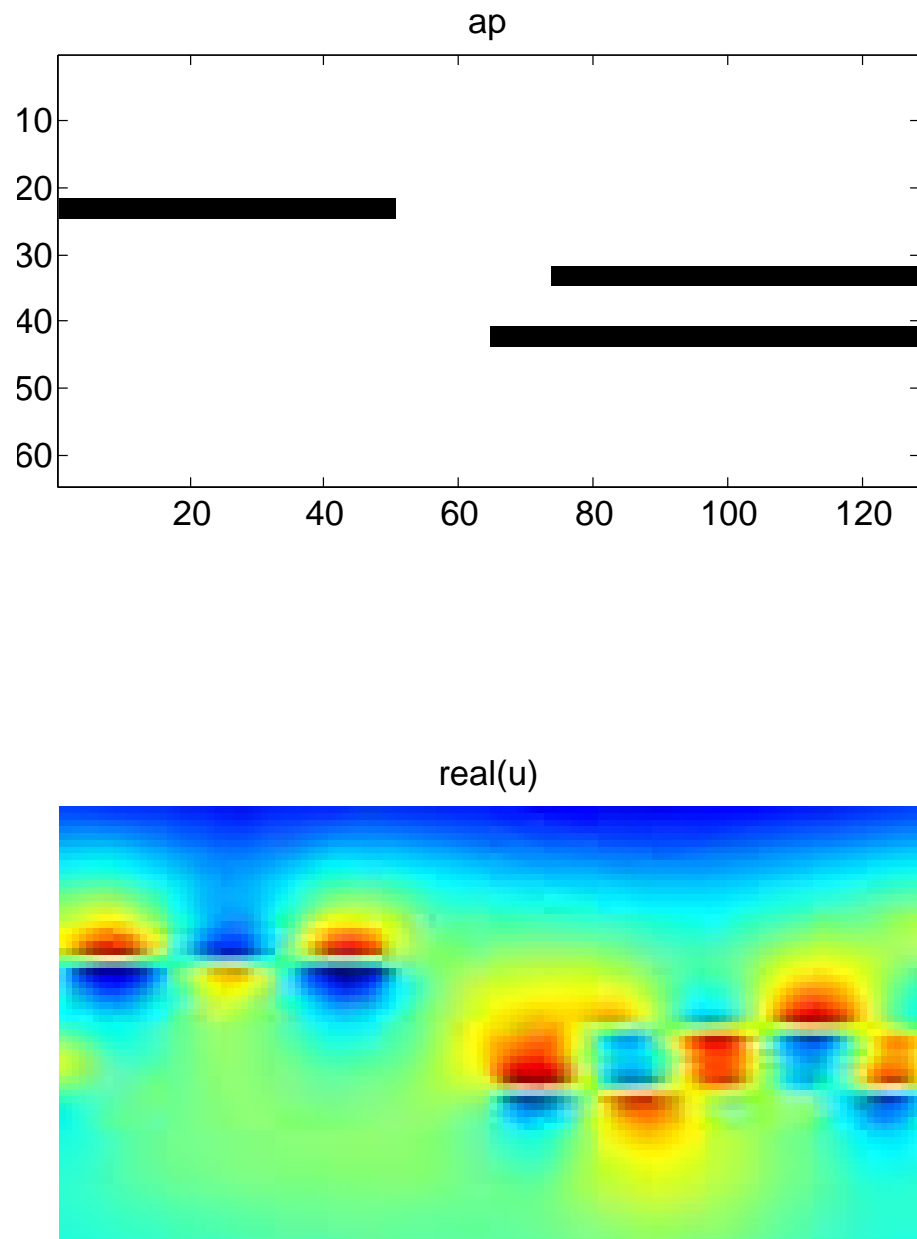

Figure 3.2. Surface plasmons (bottom) at the interface of the structure (top).

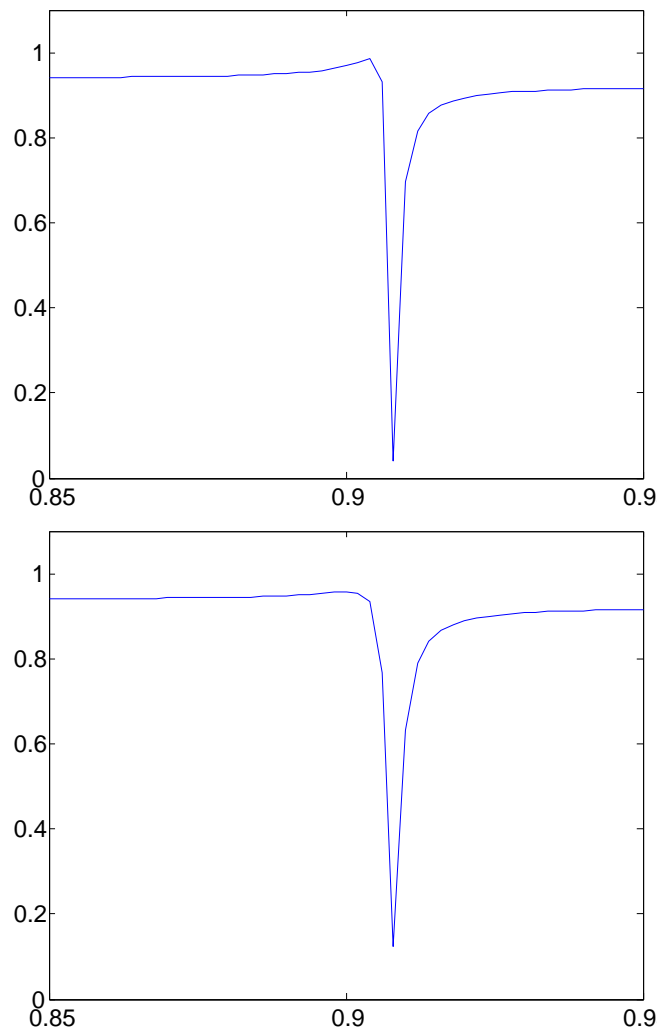

Figure 3.3. Transmission energy epectrum with imaginary part $\rho_i = 0$ (top), $\rho_i = 0.00001$ (bottom) for the structure Figure 3.5.

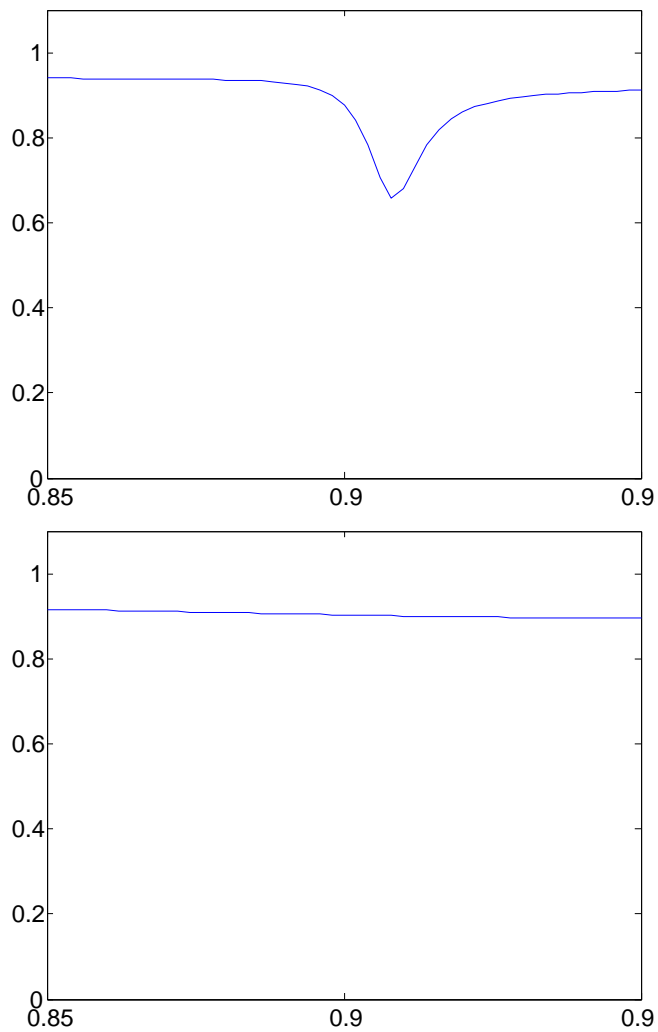

Figure 3.4. Transmission energy epectrum with imaginary part $\rho_i = 0.0001$ (top) $\rho_i = 0.002$ (bottom) for the structure Figure 3.5.

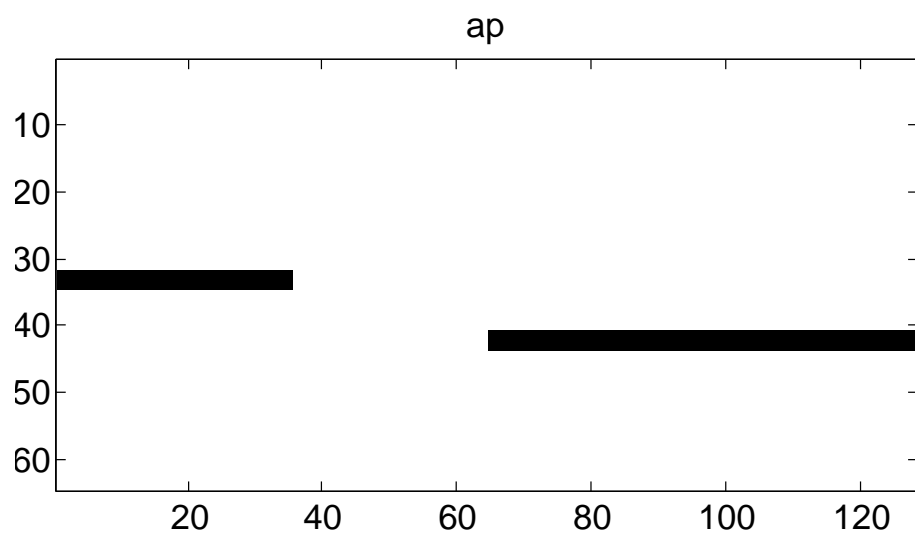

Figure 3.5. The structure for transmission energy spectrum.

CHAPTER 4

CONCLUSIONS

As the first topic, electromagnetic wave propagation through a periodic aperture array in an infinitesimally thin electric perfect conductor has been studied. We formulated the corresponding operator equation for the tangential components of the electric and magnetic fields inside the apertures. But the equation appears not to be well posed. Adding a regularization parameter $\delta > 0$, we established the solvability for the equation with a mollification parameter $\beta > 0$. The appearance of the parameter δ provides stable numerical solutions to the equation as well as solvability. Another characteristic of δ is that it gives rise to energy dissipation. The greater the value of δ is, the more energy is dissipated. Also we see that the amount of energy dissipation depends on the shape of holes in the array. Although the assumption of an infinitely thin perfect conductor is hardly attainable in practice, it is remarkable that the computed transmission spectra agree quantitatively with that of the experimental data with a good conductor of finite width, and the transmission spectra exhibit transmission resonances that are shown in the real experiment [9], which indicates that the regularized operator problem gives a reasonable approximation to the physical system. We presented the boundary conditions associated with the regularized operator. We wish to show that, with those boundary conditions, the parameter δ produces energy dissipation, and how much energy is dissipated, depending on the parameter, through further work.

As the second model, we investigated a more plausible model with volumetric media, restricted to a two-dimensional geometry. Most metals have a negative real value with positive imaginary part in their permittivities in at least part of the electromagnetic spectrum. Hence it is important to examine electromagnetic wave propagation through interfaces between media with opposite signs for dielectric constants. We formulated the scattering problems for TE-, TM-polarizations and proved the existence and uniqueness of solutions to the variational problems corresponding to each polarization. Allowing a positive imaginary part for the dielectric coefficient that accounts for energy absorption

makes our model physically plausible, and the appearance of it guarantees the coercivity of the variational problems. We presented the problem of designing an optimal structure for which a desired energy transmission spectrum is attained. The optimal design problem is stated as a minimization problem, and we showed that the minimization problem has at least one solution for an appropriate admissible set. We showed numerical experiments of the transmission energy spectrum for several structures. We see that the transmission energy spectrum exhibits some similar peaks as our first model and experimental data introduced in Section 1.3, even though they are not comparable because the model is in the two-dimensional geometry. It is known that the surface plasmon polariton, a collection of excitations of the conduction electron gas, occurs at the interface of dielectrics and good conductors. We presented a numerical experiment that shows the appearance of the surface plasmon polaritons at the interface of the structure. Our research of the optimization problem is still going on now and we expect to find an effective numerical method utilizing a more feasible admissible set.

REFERENCES

- [1] Robert A. Adams. *Sobolev Spaces*. Academic Press. (1975)
- [2] H. A. Bethe. *Theory of Diffraction by Small Holes*. Phys. Rev. **66**, 163-182 (1944)
- [3] Gang Bao, Lawrence Cowsar, & Wen Masters. *Mathematical Modeling in Optical Science*. SIAM., (2001)
- [4] Gang Bao. *Finite Element Approximation of Time Harmonic Waves in Periodic Structures*. SIAM J. Numer. Anal., **32** 1155-1169 (1995)
- [5] Oscar P. Bruno & Stéphane Lintner. *Superlens-cloaking of small dielectric bodies in the quasistatic regime*. J. Appl. Phys. **102** 124502 (2007)
- [6] A. S. Bonnet-Ben Dhia, P. Ciarlet, & Jr. C. M. Zwölf *Two- and three-field formulations for wave transmission between media with opposite sign dielectric constants*. J. of Comp. and Appl. Math. **204** 408-417 (2007)
- [7] A. S. Bonnet-Ben Dhia, P. Ciarlet, & Jr. C. M. Zwölf *Time harmonic wave diffraction problems in materials with sign-shifting coefficients*. Journal of Computational and Applied Mathematics. **234** 1912-1919 (2009)
- [8] Hua Cao & Ajay Nahata. *Resonantly enhanced transmission of terahertz radiation through a periodic array of subwavelength apertures*. Optics Express. **12** 1004-1010 (2004)
- [9] Hua Cao & Ajay Nahata. *Influence of aperture shape on the transmission properties of a periodic array of subwavelength apertures*. Optics Express. **12** 3664-3672 (2004)
- [10] Xinfu Chen & Avner Friedman. *Maxwell's Equations in a Periodic Structure*. Transactions of the American Mathematical Society. **323**, 465-507 (1991)
- [11] B. Dacorogna. *Direct Methods in the Calculus of Variations*. Springer-Verlag. (1989)
- [12] David C. Dobson, Eddie Wadbro. *Optimization of transmission spectra through periodic aperture arrays*. Preprint.
- [13] David C. Dobson & Avner Friedman. *The Time-Harmonic Maxwell equations in a Doubly Periodic Structure*. Journal of Mathematical Analysis and Applications. **166**, 507-528 (1992)
- [14] David C. Dobson. *Optimal design of periodic antireflective structures for the Helmholtz equation*. Euro. Jnl of Applied Mathematics **4**, 321-340 (1993)
- [15] T.W. Ebbesen, H.J. Lezec, H.F. Ghaemi, T. Thio, & P.A. Wolff. *Extraordinary optical transmission through subwavelength hole arrays*. Nature. **391**, 667-669 (1998)

- [16] Lawrence C. Evans. *Partial Differential Equations*. American Mathematical Society (1998)
- [17] U. Fano *Effects of configuration interaction on intensities and phase shifts*. Phys. Rev. Letter. **124** 1866-1878 (1961)
- [18] Loukas Grafakos. *Classical and Modern Fourier Analysis*. Pearson Education. (2004)
- [19] Charles Kittel. *Introduction to solid state physics*. John Wiley & Sons. (2004)
- [20] A. Krishnan, T. Thio, T.J. Kim, H.J. Lezec, T.W. Ebbesen, P.A. Wolff, J. Pendry, L. Martin-Moreno & F.J. Garcia-Vidal. *Evanescence coupled resonance in surface plasmon enhanced transmission*. Optics Comm. **200**, 1-7 (2001)
- [21] K.J. Klein Koerkamp, S. Enoch, F.B. Segerink, N.F. van Hulst & L. Kuipers. *Strong Influence of Hole Shape on Extraordinary Transmission through Periodic Arrays of Subwavelength Holes*. Phys. Rev. Letter. **92** 183901 1-4 (2004)
- [22] R.V. Kohn, H. Shen, M.S. Vogelius & M.I. Weinstein. *Cloaking via change of variables in electric impedance tomography*. Inverse Problems. **24**, 015016 (2008)
- [23] Peter Kuchment. *Floquet Theory for Partial Differential Equations*. Birkhäuser. (1993)
- [24] Tatsunosuke Matsui, Amit Agrawal, Ajay Nahata & Z. Vally Vardeny. *Transmission resonances through aperiodic arrays of subwavelength apertures*. Nature. **446**, 517-521 (2007)
- [25] G.W. Milton & N.P. Nicorovici *On the cloaking effects associated with anomalous localized resonance*. Royal Soc. Lon. Proceed. Series A., **461** 3999-4034 (2005)
- [26] Peter Monk. *Finite Element Methods for Maxwell's Equations*. Oxford Science Publications., (2003)
- [27] Hans E. J. Neugebauer. *Diffraction of Electromagnetic Waves Caused by Apertures in Absorbing Plane Screens*. IRE Transactions on Antennas and Propagation., 115-119 (1956)
- [28] J.B. Pendry. *Negative refraction makes a perfect lens*. Phys. Rev. Letter. **85** 3966-3969 (2000)
- [29] J.B. Pendry, D. Schurig & D.R. Smith. *Controlling Electromagnetic Fields*. Science. **312** 1780-1782 (2006)
- [30] Stefan Alexander Maier. *Plasmonics, Fundamentals and Applications*. Springer. (2007)
- [31] M. Sarrazin, Jean-Pol Vigneron & Jean-Marie Vigoureux. *Role of Wood anomalies in optical properties of thin metallic films with a bidimensional array of subwavelength holes*. Phys. Rev. **67**, 085415 1-8 (2003)
- [32] J. A. Stratton & L. J. Chu. *Diffraction Theory of Electromagnetic Waves*. Phys. Rev. **56**, 99-107 (1939)
- [33] Michael E. Taylor. *Pseudodifferential Operators*. Princeton University Press. (1981)

- [34] F.G. Vasquez, G.W. Milton & D. Onofrei. *Active Exterior Cloaking for the 2D Laplace and Helmholtz Equations*. *Phy. Rev. Lett.* **103**, 073901 (2009)
- [35] V.G. Veselago. *The electrodynamics of substances with simultaneously negative values of ϵ and μ* . *Uspekhi Fizicheskikh Nauk* **92**, 517-526 (1968). (Transl. *Soviet Phys. Uspekhi* **10** 509-514 (1968))